

Ball type A

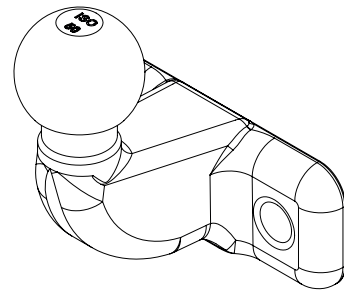

Ball type B

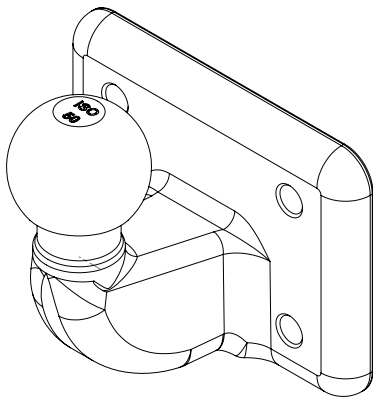

Ball type C

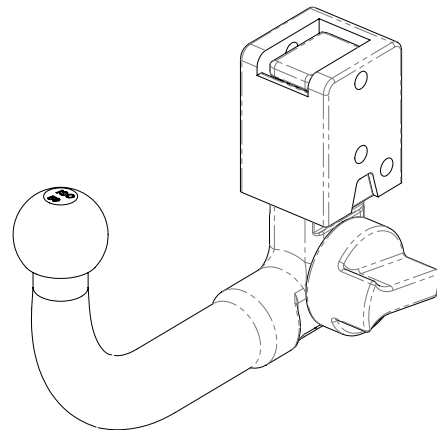

Ball type V



TRUMPF
TruLaser Tube 7000



PRESS BRAKE
TruBend 3120

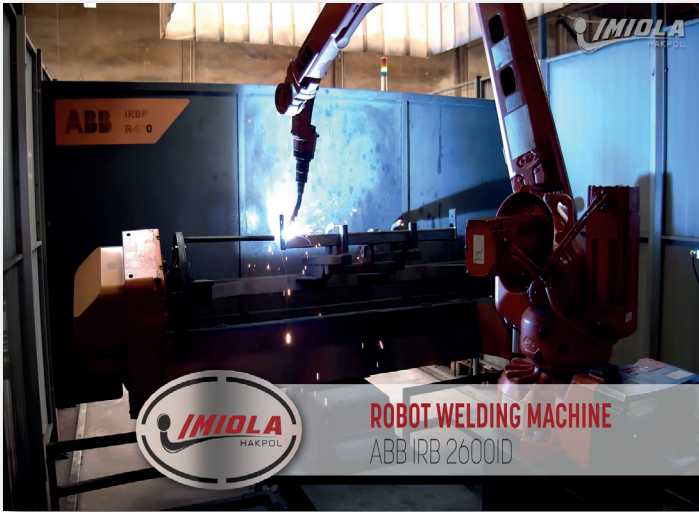

ROBOT WELDING MACHINE
ABB IRB 2600ID



EPOXY
Powder paint

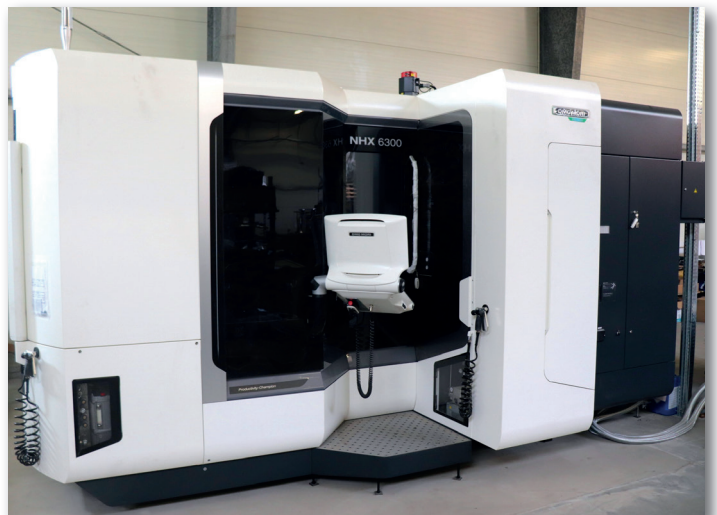
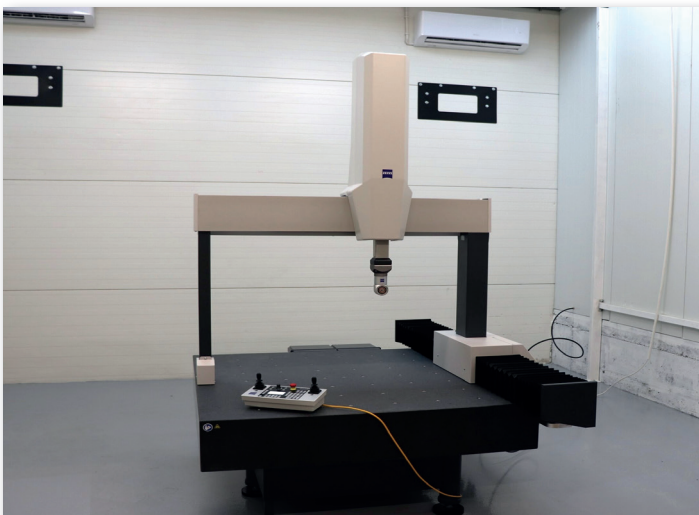



Imiola HAK-POL a été créée en 1991. Nous sommes spécialisés dans la fabrication d'attache-remorques et proposons plus de cinq cents modèles pour voitures de tourisme et véhicules utilitaires. Pour assurer à la fois la qualité et la précision de nos produits, les éléments nécessaires à la production d'attache-remorques sont fabriqués à l'aide de machines modernes à commande numérique (CNC) telles que des découpeuses au laser, des postes de soudage robotisés et des presses plieuses. Pour assurer la meilleure tenue dans le temps, nos attelages, après grenailage et phosphatation reçoivent une couche de peinture en poudre polyester.

La société HAK-POL a mis en place et utilise un système de gestion de la qualité répondant aux exigences de: PN- EN ISO 9001: 2015-10 dans le domaine de la conception, fabrication, vente de barres de remorquage et service de coupe au laser.

Tous nos produits disposent de l'homologation européenne e20 et E20. De plus, nous possédons un certificat EAC attestant que le produit est conforme aux normes de qualité et de sécurité des marchés des États membres de l'Union Douanière Eurasiatique.

Afin d'obtenir les homologations, nos attelages sont testés par le laboratoire PIMOT: institution habilitée par le ministère de l'Infrastructure à fournir et à délivrer de telles certifications.

En vertu de notre accord, PIMOT Varsovie assure le suivi de la qualité de nos produits.

Nous commercialisons actuellement nos attache-remorques dans 12 pays européens avec un succès toujours croissant.



Imiola HAK-POL werd in 1991 opgericht. We zijn gespecialiseerd in het produceren van trekhaken en bieden meer dan vijfhonderd modellen aan voor bedrijfswagen en toerisme wagens. Om zowel de kwaliteit als de precisie van onze producten te garanderen, worden de nodige elementen voor het produceren van trekhaken, aan de hand van moderne machines (CNC) gemaakt zoals lasersnijders, robot lasmachines en afkantpersen. De beste duurzaamheid garanderen we met een laag polyesterpoederverf na het gritstralen en een fosfaatbehandeling van onze koppelingen.

HAK-POL heeft een kwaliteitsmanagementsysteem geïmplementeerd dat voldoet aan de vereisten van: PN- EN ISO 9001: 2015-10 op het gebied van ontwerpen, produceren en verkopen van trekhaken en lasersnijservice.

Al onze producten hebben de Europese goedkeuring e20 en E20. Daarnaast hebben we een EAC-certificaat waaruit blijkt dat het product voldoet aan de kwaliteits- en veiligheidsnormen van de markten van de lidstaten van de Euraziatische douane-unie.

Om goedkeuringen te verkrijgen worden onze koppelingen getest door het PIMOT-laboratorium, instelling die door het ministerie van Infrastructuur gemachtigd is om dergelijke goedkeuringen en certificaten te verstrekken.

Krachtens de overeenkomst, PIMOT Warschau verzekert de kwaliteitscontrole van onze producten.

Momenteel verkopen we onze trekhaken in 12 Europese landen met toenemend succes.



Imiola HAK-POL was established in 1991. We specialize in manufacturing tow bars for over five hundred models of passenger cars and delivery vans. To ensure both high quality and precision of our products the elements needed for tow bars production are made with the use of modern CNC (Computer Numerically Controlled) machines such as laser cutting machines, robotic welding stand and punching press. To ensure the best possible protection for our tow bars they are cleaned in the blast cleaning chamber and phosphor coated before receiving their final coat of polymer powder paint.

HAK-POL company has implemented and uses a management system satisfying the requirements of: PN- EN ISO 9001:2015-10 – the scope of certification: DESIGN, MANUFACTURE AND SALE OF TOW BARS AND LASER CUTTING SERVICES.

The quality of our products is confirmed by the e20 and E20 EU approvals. Additionally, we possess an EAC certificate that confirms that the product is compliant with quality and safety standards that are binding on the markets of the Customs Union Member States, i.e. Russia, Kazakhstan and Belarus.























In order to obtain homologations our tow bars are tested by the Automotive Industry Institute (PIMOT) laboratory. The PIMOT laboratory is the institution authorized by the Ministry of Infrastructure to provide and grant such certifications.

Under the agreement, the Automotive Industry Institute (PIMOT) in Warsaw keeps control over our production.

























































We currently sell our products in 12 European countries from which we receive an ever increasing amount of interest.

 BRAND & MODEL	building year 	CAT NO.	 type of coupling	 vertical load	 max. towing weight	D-Value (kN)	electr. module	 bumper cut
ALFA ROMEO								
GIULIA (4D)	05/2016-	AR/004		100	1700	9,50	M	
		AR/A04		100	1700	9,50	M	
STELVIO (SUV) (excl. 2,9 V6 GME BI-TURBO QU-ADRIFOGLIO)	11/2016-	AR/005		120	2400	11,80	M	
		AR/A05		120	2400	11,80	M	
AUDI								
80 (B-4) excl. CABRIO	11/91-95	A/004		75	1865	9,90		
A1 (excl. S1, Quattro)	07/10-10/18	Z/025		85	1415	7,50	M	
		Z/A25		85	1415	7,50	M	
A3	09/96-04/03	W/018		75	1650	9,06		
A3 (excl. Sportback, RS3, S3)	05/03-04/12	W/028		75	1850	9,20	M	
A3 (Cabrio, Limusine) (incl.S-line) (excl. Sportback)	05/12-11/19	Z/016		100	1800	9,50	M	
		Z/A16		100	1800	9,50	M	
A4 B5 saloon (incl. Quattro) (excl. S4, RS4)	11/94-10/00	A/010		75	1800	9,47		
A4 B5 avant (incl. Quattro) (excl. S4, RS4)	01/96-08/01	A/010		75	1800	9,47		
A4 B6 saloon (incl. Quattro) (excl. S4, RS4)	11/00-09/04	A/011		80	2000	10,71	M	
		A/A11		75	1800	9,47	M	
A4 B6 avant (incl. Quattro) (excl. S4, RS4)	09/01-09/04	A/011		80	2000	10,71	M	
		A/A11		75	1800	9,47	M	
A4 B7 saloon (incl. Quattro) (excl. S4, RS4)	10/04 - 03/07	A/011		80	2000	10,71	M	
		A/A11		75	1800	9,47	M	
A4 B7 avant (incl. Quattro) (excl. S4, RS4)	10/04 - 03/08	A/011		80	2000	10,71	M	
		A/A11		75	1800	9,47	M	
A4 B8 saloon (excl. S-line, S4)	11/07-09/15	A/014		90	2100	10,90	M	
		A/A14		90	2100	10,90	M	
A4 B8 avant (excl. S-line, S4)	04/08 - 09/15	A/014		90	2100	10,90	M	
		A/A14		90	2100	10,90	M	
A4 B9 saloon (incl. Quattro)(excl. S4, RS4, g-tron)	10/15-	A/023		95	2100	11,00	M	
		A/A23		95	2100	11,00	M	
A4 B9 avant (incl. Quattro)(excl. S4, RS4, g-tron)	10/15-	A/023		95	2100	11,00	M	
		A/A23		95	2100	11,00	M	
A5 coupe; sportback (excl. S-line, S5)	06/07-05/16	A/014		90	2100	10,90	M	
		A/A14		90	2100	10,90	M	
A5 F5 coupe; sportback (incl.Quattro)(excl. G-tron)	06/16-	A/023		95	2100	11,00	M	
		A/A23		95	2100	11,00	M	
A6 C5 saloon (incl. Quattro) (excl. RS6)	06/98-03/05	A/008		85	2055	10,90		-
A6 C5 avant (incl. Quattro) (excl. RS6)	04/97 - 04/04	A/008		85	2055	10,90		-
A6 C6 saloon (incl. Quattro) (excl. RS6, Air suspension)	05/04 - 03/11	A/012		85	2100	10,90	M	
		A/A12		85	2100	10,90	M	



















































 BRAND & MODEL	building year 	CAT NO.	 type of coupling	 vertical load	 max. towing weight	D-Value (kN)	electr. module	 bumper cut
A6 C6 avant (incl. Quattro) (excl. RS6, Air suspension)	03/05 - 08/11	A/012		85	2100	10,90	M	
		A/A12		85	2100	10,90	M	
A6 C7 saloon (incl. Quattro, S-line) (excl. RS6)	04/11-06/18	A/019		100	2500	12,60	M	
		A/A19		100	2500	12,60	M	
A6 C7 avant (incl. Quattro, S-Line) (excl. RS6)	09/11-04/18	A/019		100	2500	12,60	M	
		A/A19		100	2500	12,60	M	
A6 C8 saloon (incl. Quattro, MHEV, S-Line, Smart opener system)	06/2018-	A/026		135	2100	11,50	M	
		A/A26		135	2100	11,50	M	
A6 C8 avant (incl. Quattro, MHEV, S-Line, Smart opener system)	06/2018-	A/026		135	2100	11,50	M	
		A/A26		135	2100	11,50	M	
A7 Sportback (incl. Quattro, S-line) (excl. RS7)	09/10-03/18	A/019		100	2500	12,60	M	
		A/A19		100	2500	12,60	M	
A8 saloon (incl. Quattro, Long)	03/10-10/17	A/022		100	2300	12,60	M	
		A/A22		100	2110	12,00	M	
Q2 (incl. S-line)	09/16-	Z/016		100	1800	9,50	M	
		Z/A16		100	1800	9,50	M	
Q3 (incl. S-line) (excl. RS, Quattro)	10/11-11/18	W/033		100	2500	12,00	M	
		W/A33		100	2500	12,00	M	
Q3 (F3B) (incl. Adblue)	07/18-	A/025		120	2500	12,60	M	
		A/A25		120	2500	12,60	M	
Q5 8R (excl. SQ5)	09/08 -12/16	A/016		100	2400	11,88	M	
		A/A16		100	2400	11,88	M	
Q5 (FY) (excl. SQ5)	01/17-	A/021		100	2400	12,70	M	
		A/A21		100	2400	12,70	M	
Q7 (4L) (excl. panorama sunroof)	01/06-06/15	A/015		140	3500	16,40	M	
		A/A15		140	3500	16,40	M	
Q7 (4MB)	07/15-	A/017		140	3500	16,40	M	
		A/A17		140	3500	16,40	M	
BMW								
1 -SERIES (E81)(E87)	09/04-08/11	B/010		75	1900	10,00	M	-
		B/A10		75	1900	10,00	M	-
1 - SERIES (F20/F21) (excl. M1, M135i, M140i, M240i)	09/11-06/19	B/021		100	1944	10,00	M	-
		B/A21		100	1944	10,00	M	-
2 -SERIES (F22) Coupe (incl. M-Pakiet)	07/14-	B/021		100	1944	10,00	M	-
		B/A21		100	1944	10,00	M	-
2 -SERIES (F45) Active Tourer (excl. 225xe)	03/14-	B/021		100	1944	10,00	M	-
		B/A21		100	1944	10,00	M	-
2 -SERIES (F46) Grand Tourer	03/15-	B/021		100	1944	10,00	M	-
		B/A21		100	1944	10,00	M	-
3 - SERIES E36 estate (excl. M3, M-Pakiet)	01/95-08/99	B/001		80	1800	9,30		
3 - SERIES E36 saloon (excl. M3, M-Pakiet)	09/90-12/97	B/001		80	1800	9,30		

 BRAND & MODEL	building year 	CAT NO.	 type of coupling	 vertical load	 max. towing weight	D-Value (kN)	electr. module	 bumper cut
3-SERIES E36 Coupe (excl. M3, M-Pakiet)	03/92-04/99	B/001		80	1800	9,30		
3 - SERIES E36 compact (excl. M3, m-Pakiet))	05/94-07/01	B/012		75	1600	8,20		
3 - SERIES E46 saloon (excl. M3, M-Pakiet, 3.0xd 150kw)	01/98-01/05	B/007		75	1800	9,51	M	
3 - SERIES E46 compact (excl. M3, M-Pakiet, 3.0xd 150kw)	07/01-02/05	B/007		75	1800	9,51	M	
3 - SERIES E46 coupe (excl. M3, M-Pakiet, 3.0xd 150kw)	04/99-07/06	B/007		75	1800	9,51	M	
3 - SERIES E46 estate (excl. M-Pakiet, 3.0xd 150kw)	10/99-08/05	B/011		75	1865	9,69	M	-
3 - SERIES E90 saloon (excl. 335i/335d, M3)	02/05-02/12	B/010		75	1900	10,00	M	-
		B/A10		75	1900	10,00	M	-
3 - SERIES E91 estate (excl. 335i/335d, M3)	09/05-08/12	B/010		75	1900	10,00	M	-
		B/A10		75	1900	10,00	M	-
3 - SERIES F30 saloon (excl. M3, Active Hybrid)	03/12-10/18	B/021		100	1944	10,00	M	-
		B/A21		100	1944	10,00	M	-
3 - SERIES F31 estate (excl. M3,Active Hybrid)	09/12-06/18	B/021		100	1944	10,00	M	-
		B/A21		100	1944	10,00	M	-
3 - SERIES F34 Gran Turismo	13-	B/028		85	1950	10,50	M	-
		B/A28		85	1950	10,50	M	-
3 - SERIES G20 saloon	11/18-	B/031		100	2000	10,50	M	-
		B/A31		100	2000	10,50	M	-
3 - SERIES G21 estate	07/19-	B/031		100	2000	10,50	M	-
		B/A31		100	2000	10,50	M	-
4 - SERIES F32 coupe (excl. M4)	09/13-	B/021		75	1944	10,00	M	-
		B/A21		75	1944	10,00	M	-
4 - SERIES F33 cabrio (excl. M4)	03/14-	B/021		75	1944	10,00	M	-
		B/A21		75	1944	10,00	M	-
4 - SERIES F36 grand coupe (excl. M4)	06/14-	B/021		75	1944	10,00	M	-
		B/A21		75	1944	10,00	M	-
5 - SERIES E39 saloon (excl. M-Pakiet bumper)	12/95-10/03	B/004		90	2100	10,30		
5 - SERIES E39 estate (excl. M-Pakiet bumper)	03/97-05/04	B/005		90	1800	10,65		
5 - SERIES E60 saloon (excl. M5, M-Pakiet)	07/03-02/10	B/008		90	2000	11,40	M	-
		B/A08		90	2000	11,40	M	-
5 - SERIES E61 estate (excl. M5, M-Pakiet)	06/04-08/10	B/008		90	2000	11,40	M	-
		B/A08		90	2000	11,40	M	-
5 - SERIES F10 saloon (excl. M5, Active Hybrid)	03/10-02/17	B/020		100	2200	11,80	M	-
		B/A20		100	2200	11,80	M	-
5 - SERIES F11 estate (excl. M5, Active Hybrid)	09/10-05/17	B/020		100	2200	11,80	M	-
		B/A20		100	2200	11,80	M	-

























































 BRAND & MODEL	building year 	CAT NO.	 type of coupling	 vertical load	 max. towing weight	D-Value (kN)	electr. module	 bumper cut
5 – SERIES G30 saloon (excl. M5)	09/16-	B/023		100	2200	11,80	M	
		B/A23		100	2200	11,80	M	
5 – SERIES G31 estate (excl. M5)	03/17-	B/023		100	2200	11,80	M	
		B/A23		100	2200	11,80	M	
6 – SERIES G32 GT excl. M6	06/17-	B/023		100	2200	11,80	M	
		B/A23		100	2200	11,80	M	
7- SERIES F01 saloon	11/08-02/15	B/029		100	2300	12,15	M	
		B/A29		100	2300	12,15	M	
X1 E84 (excl. M-Pakiet)	11/09-09/15	B/016		85	2000	10,85	M	-
X1 F48	07/15-06/22	B/024		85	2000	10,40	M	
		B/A24		85	2000	10,40	M	
X1 (U11) (incl. Mild hybrid, M-Pakiet)	07/22-	B/032		80	2025	11,60	M	
		B/A32		80	2025	11,60	M	
iX1 (U11) (incl. M-Pakiet)	08/22-	B/032		80	1200	8.03	M	
		B/A32		80	1200	8.03	M	
X2 F39 (incl. M-Pakiet)	01/18-	B/027		130	2500	12,00	M	
		B/A27		130	2500	12,00	M	
X3 E83 (excl. M-Pakiet)	01/04-10/10	B/009		80	2000	10,85	M	-
		B/A09		80	2000	10,49	M	
X3 F25 (incl. M-Pakiet) (excl. X3M)	11/10-10/17	B/017		100	2400	12,11	M	
		B/A17		100	2400	12,11	M	
X4 F26 (excl. X4M)	07/14-03/18	B/017		100	2400	12,11	M	
		B/A17		100	2400	12,11	M	
X4 G02 (incl. M-Pakiet, X-Line)	04/18-	B/030		120	2500	12,60	M	
		B/A30		120	2500	12,60	M	
X5 E53 (excl. M-Pakiet)	06/00-02/07	B/A13		120	3500	13,50	M	-
X5 E70 (incl. M-Pakiet)	03/07-10/13	B/014		150	3500	16,53	M	
		B/A14		150	3500	16,53	M	
X5 (F15/F85) (incl. M-Pakiet)	11/13-07/18	B/014		150	3500	16,53	M	
		B/A14		150	3500	16,53	M	
X5 G05 (incl. M-Pakiet)	08/18-	B/026		200	3500	16,40	M	-
		B/A26		140	3500	16,40	M	-
X6 E71	01/08-10/14	B/018		140	3500	16,00	M	
		B/A18		140	3500	16,00	M	
X6 (F16/F86) (incl. M-Pakiet)	11/14-07/19	B/014		150	3500	16,53	M	
		B/A14		150	3500	16,53	M	
X6 (G06/F96) (incl. M-Pakiet)	08/19-	B/026		200	3500	16,40	M	-
		B/A26		140	3500	16,40	M	-
X7 G07	03/19-	B/026		200	3500	16,40	M	-
		B/A26		140	3500	16,40	M	-
CHEVROLET								
AVEO htb. 3/5D	04/08-06/11	CH/010		50	1200	6,60		

 BRAND & MODEL	building year 	CAT NO.	 type of coupling	 vertical load	 max. towing weight	D-Value (kN)	electr. module	 bumper cut
AVEO htb.	03/11-	CH/014		44	1100	6,62	M	-
CAPTIVA (C100) (C140)	06/06-	CH/009		80	2000	11,00	M	
		CH/A09		80	2000	11,00	M	
CRUZE saloon (J300)	05/09-	CH/012		75	1800	9,60	M	
CRUZE htb. (J305)	12/10-	CH/012		75	1800	9,60	M	
EQUINOX	18-	CH/103		75	1600	8,91	M	-
EXPRESS / GMC SAVANA 2WD (23705, 23406, 23405)	97-	CH/100		180	3800	18,88		-
LACETTI estate	04-10	CH/005		75	1240	7,20		-
LACETTI 5 doors	03-10	CH/004		75	1200	7,00		-
LACETTI saloon	05-10	CH/008		75	1300	7,00		-
ORLANDO	11-	CH/011		75	1600	9,90	M	-
SILVERADO DC	14-	CH/101		140	3500	20,50	M	-
TRAILBLAZER	13-	CH/015		75	1700	10,30	M	-
TRAILBLAZER ACTIV	21-	CH/105		75	453	3,62	M	-
TRAX	13-	O/044		75	1500	8,75	M	
TRAVERSE	17-	CH/104		110	2268	12,40	M	-
CHRYSLER								
VOYAGER (excl. Stow'n Go)	05/01-01/08	CH/003		80	1600	9,90		
GRAND VOYAGER (excl. Stow'n Go)	05/01-01/08	CH/003		80	1600	9,90		
GRAND VOYAGER (incl. Stow'n Go)	02/08-	CH/025		140	2025	11,53	M	-
		CH/A25		140	2025	11,53	M	-
GRAND VOYAGER LWB (incl. Stow'n Go)	05-02/08	CH/022		80	1800	10,70	M	
PACIFICA	01/03-11/07	CH/024		80	1800	11,00		-
PACIFICA	16-	CH/026		90	1800	10,63	M	
		CH/A26		90	1800	10,63	M	
CITROEN								
BERLINGO (incl. MPV)	11/96-04/08	C/012		70	1100	7,00		-
BERLINGO II (L1=4380mm)	05/08-03/18	C/029		80	1600	8,69	M	-
		C/A29		80	1600	8,69	M	-
BERLINGO II (L2=4628mm)	05/08-05/18	C/036		65	1600	8,69	M	-
		C/A36		65	1600	8,69	M	-
BERLINGO III (K9) (L1=4403)	03/18-	C/029		80	1600	8,69	M	-
		C/A29		80	1600	8,69	M	-
BERLINGO III XL (L2=4753)	06/18-	C/045		75	1600	9,43	M	-
		C/A45		75	1600	9,43	M	-
C-CROSSER	02/07-08/12	Y/024		100	2000	11,00	M	
		Y/A24		100	2000	11,00	M	
C-ELYSSE	01/13-	C/040		55	1010	6,41	M	-
C-3 I htb.	02/02-12/09	C/016		50	1100	6,10	M od 2005	-
C-3 II htb.	10-09/16	C/031		54	1250	7,00	M	-







































 BRAND & MODEL	building year 	CAT NO.	 type of coupling	 vertical load	 max. towing weight	D-Value (kN)	electr. module	 bumper cut
C-3 II PICASSO	02/09-09/17	C/032		61	1200	7,20	M	
C-3 III htb.	07/16-	P/040		55	1300	7,20	M	-
		P/A40		55	1300	7,20	M	-
C-3 AIRCROSS	06/17-	C/043		55	825	5,35	M	
		C/A43		55	825	5,35	M	
C-4 AIRCROSS	03/12-	Y/028		70	1500	8,96	M	-
		Y/A28		70	1500	8,17	M	-
C-4 I htb.	10/04-10/10	C/020		66	1500	8,05	M	
C-4 II htb.	11/10-	C/033		66	1500	8,05	M	
C-4 CACTUS	09/14-	C/043		55	825	5,35	M	-
		C/A43		55	825	5,35	M	-
C-4 PICASSO	10/06-05/13	C/035		75	1800	9,71	M	-
		C/A35		75	1800	9,71	M	-
C-4 II PICASSO	06/13-03/18	C/039		70	1750	9,56	M	
		C/A39		70	1750	9,56	M	
C-4 GRAND PICASSO I	10/06-05/13	C/035		75	1800	9,71	M	-
		C/A35		75	1800	9,71	M	-
C-4 GRAND PICASSO II	09/13-03/18	C/039		70	1750	9,56	M	-
		C/A39		70	1750	9,56	M	
C-4 GRAND SPACETOURIER	03/18-	C/039		70	1750	9,56	M	-
		C/A39		70	1750	9,56	M	
C-4 III	01/21-	C/A48		75	1750	9,00	M	
C-5 I htb. (DC)	04/01-09/04	C/017		75	1700	9,32		-
C-5 I estate (DE)	00-12/04	C/021		85	1600	10,20		-
C-5 I htb. (RC)	10/04-03/08	C/022		75	1600	9,17	M	
C-5 II saloon (RD)	04/08-	C/037		80	1900	10,40	M	-
		C/A37		80	1900	10,40	M	-
C-5 II estate (RW) (excl. 2.2 HDI/3.0 HDI)	05/08-05/17	C/038		80	1900	10,40	M	-
		C/A38		80	1900	10,40	M	-
C-5 AIRCROSS (excl. Hybrid)	11/18-	P/044		100	2000	10,10	M	
		P/A44		100	2000	10,10	M	
C-5 AIRCROSS Hybrid	04/20-	P/049		80	1300	8,25	M	
		P/A49		80	1300	8,25	M	
C8	09/02-07/14	F/020		80	1900	10,20	M od 2005	
DS 3 3D (excl. Racing model)	02/10-	C/031		54	1250	7,00	M	
DS 4 5D	04/11-	C/033		66	1500	8,05	M	-
DS 5 5D (excl. Hybrid)	02/12-	C/046		75	1540	8,80	M	
		C/A46		75	1540	8,80	M	
EVASION	06/94-08/02	P/016		80	1800	9,70		
JUMPER	05/94-12/02	C/005		110	2200	12,49		-

 BRAND & MODEL	building year 	CAT NO.	 type of coupling	 vertical load	 max. towing weight	D-Value (kN)	electr. module	 bumper cut
JUMPER	01/03-06/06	C/005		110	2200	12,49		-
JUMPER II, III BUS, BOX (L1,L2,L3 excl. L4)	07/06-	C/018		150	3500	17,17	M	
JUMPER II, III pick up (L1, L2, L3, excl. L4)	04/06-	C/025		120	3100	15,09	M	-
JUMPER II, III BUS BOX (L4)	04/06-	C/030		120	3100	16,13	M	
JUMPER II, III pick up (L1, L2, L3) (extended load-carrying body)	08/06-	C/047		100	3500	17,17	M	-
JUMPY I	09/94-01/07	P/016		80	1800	9,70		
JUMPY II	02/07-04/16	F/023		80	2000	11,93	M	-
		F/A23		80	2000	11,93	M	-
JUMPY III	05/16-	C/042		100	2500	13,60	M	-
		C/A42		100	2500	13,60	M	-
NEMO	11/07-	F/027		60	1100	6,83	M	
XSARA htb.	04/97-03/05	C/013		70	1300	7,21		-
XSARA estate	01/98-08/05	C/015		70	1300	7,30		-
XSARA PICASSO	12/99-06	C/014		80	1300	7,56		-
DAEWOO								
LANOS saloon	03/97-01/04	D/005		50	1100	6,40		-
DACIA								
DOKKER (incl. Stepway)	01/13-	G/006		75	1400	7,50		-
DUSTER I 2/4WD (excl. Adblue)	04/10-12/17	G/005		75	1500	9,00	M	
DUSTER II 2/4WD (excl. Adblue)	01/18-	G/005		75	1500	9,00	M	
LOGGY (incl. Stepway)	06/12-	G/007		75	1400	8,08	M	-
LOGAN I saloon	09/04-12/12	G/002		75	1100	6,40		-
LOGAN II saloon	01/13-10/20	G/008		75	1100	6,47	M	-
LOGAN III saloon	11/20-	G/012		75	1100	6,80	M	-
		G/A12		75	1100	6,80	M	-
LOGAN MCV/express/pick-up/estate	01/07-06/13	G/003		75	1300	7,80		-
LOGAN MCV II/estate (excl. Stepway)	07/13-	G/010		75	1596	8,00	M	-
SANDERO I	02/08-12/12	G/004		75	1355	7,30		-
SANDERO II htb. (incl. Stepway)(incl. factory-fitted LPG installation)	01/13-09/20	G/009		75	1100	6,47	M	
SANDERO III	10/20-	G/013		80	1300	7,30	M	
		G/A13		80	1300	7,30	M	
DODGE								
DURANGO	12/10-	J/029		175	3500	15,70	M	-
NITRO	06/07-12/11	J/050		140	3500	14,37		
RAM 1500 DT	01/19-	AM/107		350	3500	22,50	M	-
RAM 1500 DS.	01/19-	AM/108		350	3500	22,50	M	-
RAM 1500 TRX 4WD	08/20-	AM/112		200	5000	20,20	M	-













































 BRAND & MODEL	building year 	CAT NO.	 type of coupling	 vertical load	 max. towing weight	D-Value (kN)	electr. module	 bumper cut
FIAT								
500X (incl. City Look, 4x4, Off Road Look)	07/14-	J/072		100	1535	8,70	M	
		J/A72		100	1535	8,70	M	
ALBEA	01/02-	F/021		70	1300	6,90		
BRAVO II htb.	04/07-12/14	F/024		75	1400	7,90	M	-
		F/A24		75	1400	7,90	M	
DOBLO I MPV, Cargo (119,223) (excl. CNG)	01/01-11/09	F/003		90	1300	7,58	M	
DOBLO II (263) (BOX,VAN, Maxi) (excl. CNG)	12/09-05/22	F/031		65	1620	9,79	M	
		F/A31		65	1620	9,79	M	
DOBLO III L1	06/22-	C/029		80	1600	8,69	M	-
		C/A29		80	1600	8,69	M	-
DOBLO III XL	06/22-	C/045		75	1600	9,43	M	-
		C/A45		75	1600	9,43	M	-
DUCATO II	04/94-12/02	C/005		110	2200	12,49		-
DUCATO II	01/03-06/06	C/005		110	2200	12,49		-
DUCATO III BUS, BOX (L1, L2, L3 excl. L4)	07/06-	C/018		150	3500	17,17	M	
DUCATO III BUS, BOX L4	04/06-	C/030		120	3100	16,13	M	
DUCATO III pick up (L1, L2, L3 excl. L4)	04/06-	C/025		120	3100	15,09	M	-
DUCATO III pick up (L1, L2, L3) (extended load-carrying body)	08/06-	C/047		100	3500	17,17	M	-
FIORINO	11/07-	F/027		60	1100	6,83	M	
FREEMONT	09/11-	F/033		80	1800	9,60	M	
IDEA van	01/04-	F/037		60	1200	7,20	M	
LINEA saloon	12/06-	F/025		75	1200	7,30	M	
PANDA II htb. (excl. 4x4)	09/03-02/12	F/022		60	900	6,33	M	-
PANDA III 2WD (excl. 4x4. Trekking, City Cross)	02/12-	F/032		70	1000	6,10	M	-
PUNTO I	11/93-08/99	F/006		70	1300	6,80		-
PUNTO II	09/99-09/05	F/013		60	1200	6,73		-
PUNTO 2012 htb.	08/11-	F/029		75	1300	7,10	M	
		F/A29		75	1300	7,10	M	
PUNTO EVO (excl. Abarth)	10/09-07/11	F/029		75	1300	7,10	M	
		F/A29		75	1300	7,10	M	
GRANDE PUNTO (excl. Abarth)	03/06-07/11	F/029		75	1300	7,10	M	
		F/A29		75	1300	7,10	M	
SCUDO I	02/96-01/07	P/016		80	1800	9,70		
SCUDO II	02/07-05/16	F/023		80	2000	11,93	M	
		F/A23		80	2000	11,93	M	
SEICENTO	98-03	F/012		28	400	3,46		-
SEDICI	04/06-10/14	F/026		75	1250	7,30	M	-
		F/A26		75	1250	7,30	M	-

































































 BRAND & MODEL	building year 	CAT NO.	 type of coupling	 vertical load	 max. towing weight	D-Value (kN)	electr. module	 bumper cut
SIENA	96-02	F/011		50	1300	6,97		
TALENTO (L1,L2)	06/16-	R/066		100	2100	12,21	M	-
TIPO 5D	06/16-	F/035		100	1500	8,17	M	
		F/A35		100	1500	8,17	M	
TIPO estate	01/17-	F/036		90	1500	9,00	M	
		F/A36		90	1500	9,00	M	
ULYSSE I	94-01	P/016		80	1800	9,70		
ULYSSE II	02-06/11	F/020		80	1900	10,20	M od 2005	
QUBO	11/07-	F/027		60	1100	6,83	M	
FORD								
B-MAX (JK)	10/12-10/17	E/052		65	900	6,00	M	-
		E/A52		65	900	6,00	M	-
C-MAX	01/04-06/10	E/037		75	1500	8,50	M	
		E/A37		75	1500	8,50	M	
C-MAX II	07/10-	E/037		75	1500	8,50	M	
		E/A37		75	1500	8,50	M	
ECOSPORT II	01/18-	E/066		85	1200	7,50	M	-
		E/A66		85	1200	7,50	M	-
EDGE (incl. USA SUV)	08/15-	E/058		120	2350	12,00	M	-
		E/A58		120	2350	12,00	M	-
ESCAPE (USA)	01/13-	E/051		105	2100	10,55	M	-
		E/A51		105	2100	10,55	M	-
ESCORT estate/ORION	08/90-00	E/005		50	1200	7,00		-
EXPLORER	01/11-12/15	E/060		130	2400	12,70	M	-
EXPLORER	01/21-	E/069		130	2400	12,10	M	
FIESTA htb. (MK6)	05/02-08/08	E/032		50	900	5,61		
FIESTA htb. (MK7) (excl. ST, Sport, Titanium, ECONetic)	09/08-06/17	E/046		50	900	5,70	M	-
FIESTA VII (Mk8) (excl. ST-Line)	01/17-	E/064		65	1100	6,80	M	-
		E/A64		65	1100	6,80	M	-
FOCUS I htb (excl. RS bumper)	10/98-10/04	E/023		70	1400	7,80		-
FOCUS saloon I	98-04	E/024		75	1600	8,03		-
FOCUS I estate (excl. RS bumper)	02/99-01/05	E/025		75	1400	7,40		
FOCUS II htb. (incl. CC) (excl. RS, ST)	09/04-02/11	E/037		75	1500	8,50		
		E/A37		75	1500	8,50		
FOCUS II saloon	04/05-02/11	E/044		75	1500	8,50		-
FOCUS II estate (excl. ECONetic, ST Sport)	08/04-06/12	E/036		75	1500	8,50		-
FOCUS III htb. (excl. SR, RS)	06/11-03/18	E/048		90	1865	10,10	M	
FOCUS III estate	06/11-03/18	E/047		75	1500	10,00	M	
FOCUS IV htb. (excl. ST, Active)	04/18-	E/063		100	2100	10,31	M	
		E/A63		100	2100	10,31	M	

























































 BRAND & MODEL	building year 	CAT NO.	 type of coupling	 vertical load	 max. towing weight	D-Value (kN)	electr. module	 bumper cut
FOCUS IV estate (excl. System smart opener, Vignale, ST3, Active, ST-line)	09/18-	E/068		100	2000	10,10	M	
		E/A68		100	2000	10,10	M	
FUSION	09/02-01/12	E/034		50	1050	6,50		-
GALAXY (WGR)	06/96-05/00	E/010		85	2100	11,20		-
GALAXY (WGR)	05/00-06/06	E/030		100	2100	12,50		-
GALAXY (WM,WA6)	07/06-06/15	E/038		100	2640	12,50	M	-
		E/A38		100	2640	12,50	M	
GALAXY (CK)	05/15-	E/056		90	2287	12,10	M	
		E/A56		90	2287	12,10	M	
KUGA I	05/08-12/12	E/042		100	2100	10,50	M	
		E/A42		100	2100	10,50	M	-
KUGA II	03/13-06/19	E/051		105	2100	10,55	M	
		E/A51		105	2100	10,55	M	
KUGA III (DFK) (incl. Mild Hybrid, Plug-in Hybrid)	07/19-	E/070		100	2170	11,00	M	
		E/A70		100	2170	11,00	M	
MONDEO II estate (excl. ST200, ST220,RS)	05/93-09/00	E/028		75	2000	11,00		-
MONDEO III estate (excl. ST200, ST220, RS)	10/00-12/06	E/028		75	2000	11,00		
MONDEO III saloon (excl. ST220, Titanium, Platinum, Ghia)	10/00-12/06	E/033		80	1800	11,00		
MONDEO III htb. (excl. ST220, Titanium, Platinum, Ghia)	10/00-12/06	E/033		80	1800	11,00		
MONDEO IV estate	03/07-09/14	E/041		80	2120	11,60	M	
		E/A41		80	2120	11,60	M	
MONDEO IV saloon	03/07-09/14	E/041		80	2120	11,60	M	-
		E/A41		80	2120	11,60	M	-
MONDEO IV htb.	03/07-09/14	E/041		80	2120	11,60	M	-
		E/A41		80	2120	11,60	M	-
MONDEO V estate (excl. hybrid drive, Vignale)	09/14-	E/057		100	2532	11,90	M	
		E/A57		100	2532	11,90	M	
MONDEO V saloon (excl. hybrid drive, Vignale)	09/14-	E/057		100	2532	11,90	M	
		E/A57		100	2532	11,90	M	
MONDEO V htb. (excl. hybrid drive, Vignale)	09/14-	E/057		100	2532	11,90	M	
		E/A57		100	2532	11,90	M	
MAVERICK SUV	06/93-04/01	N/021		100	2600	12,75		-
RANGER Pick up (2/4 WD)	04/97-12/11	E/043		115	3000	15,01		-
RANGER Pick up (TKE) (excl. pipe)	01/12-	E/050		225	3500	17,20	M	-
S MAX (excl. Expression, Individual, Titanium S)	05/06-12/14	E/038		100	2640	12,50	M	
		E/A38		100	2640	12,50	M	
S-MAX	01/15-	E/056		90	2287	12,10	M	
		E/A56		90	2287	12,10	M	
TRANSIT	01/86-04/00	E/026		75	2000	12,50		-





























































 BRAND & MODEL	building year 	CAT NO.	 type of coupling	 vertical load	 max. towing weight	D-Value (kN)	electr. module	 bumper cut
TRANSIT (excl. CNG, 2,6 107KW, ECOnetic)	05/00-08/14	E/027		112	2800	15,33		-
TRANSIT VAN (excl. Turneo)	05/14-	E/054		140	3500	19,80	M	
TRANSIT VAN, with footboard	05/00-08/14	E/040		112	2800	15,33		-
TRANSIT CONNECT I	01/03-12/13	E/055		75	1250	8,10		-
TRANSIT CONNECT II	01/14-	E/053		75	1250	8,30	M	-
TRANSIT CUSTOM	01/13-	E/049		115	2800	14,91	M	-
TRANSIT COURIER	02/14-	E/067		75	1200	7,10	M	-
		E/A67		75	1200	7,10	M	-
TOURNEO CONNECT I	01/03-12/13	E/055		75	1250	8,10		-
TOURNEO CONNECT II	01/14-01/22	E/053		75	1250	8,30	M	-
TOURNEO CONNECT III	01/22-	W/056		119	1620	9,80	M	-
		W/A56		119	1620	9,80	M	-
TOURNEO CUSTOM	01/13-	E/049		115	2800	14,91	M	-
TOURNEO COURIER	02/14-	E/067		75	1200	7,10	M	-
		E/A67		75	1200	7,10	M	-
HONDA								
ACCORD VI (CG, CH)	10/98-01/03	H/008		60	1500	8,32		
ACCORD VII saloon (excl. Type S)	12/02-07/08	H/010		75	1500	8,35		
ACCORD VII estate	12/02-07/08	H/011		75	1500	8,51		
ACCORD SEDAN, TOURER	08-	H/022		75	1700	9,41	M	
CIVIC 4D	04/06-08/11	H/025		75	1700	8,80		
CIVIC 4D	12-05/17	H/026		75	1700	8,80	M	
		06/17-	H/030		100	1500	9,65	M
CIVIC 4D	06/17-	H/A30		100	1500	9,65	M	
		CIVIC 5D	01/06-12/11	H/029		75	1700	8,80
CIVIC 5D	01/12-14	H/A29		75	1700	8,80	M	
		CIVIC 5D	01/12-14	H/027		75	1500	8,32
CIVIC 5D HB excl. TYPE R	01/17-	H/031		100	1500	8,50	M	
		H/A31		100	1500	8,50	M	
CRV I	06/97-02/02	H/012		70	1500	8,00		-
CRV II	09/01-07/07	H/013		100	1500	8,65		
CRV III	01/07-09/12	H/015		100	2000	10,43		
CRV IV	11/12-08/18	H/023		100	2000	10,39	M	
CRV V (incl. Hybrid)	10/18-	H/032		100	2005	10,95	M	
		H/A32		100	2005	10,95	M	
HR-V II (excl. Sport)	11/14-	H/028		70	1400	7,85	M	
		H/A28		70	1400	7,85	M	
JAZZ 5D, van	01/15-	H/034		75	1100	6,60	M	
		H/A34		75	1100	6,60	M	
HYUNDAI								
ACCENT III saloon	06/06-01/11	J/030		50	1400	7,50		-

















































 BRAND & MODEL	building year 	CAT NO.	 type of coupling	 vertical load	 max. towing weight	D-Value (kN)	electr. module	 bumper cut
ACCENT III htb.	06/06-01/11	J/030		50	1400	7,50		-
BAYON	03/21-	J/086		85	1400	7,60	M	
		J/A86		85	1400	7,60	M	
ELANTRA	02/16-	J/081		115	1500	8,30	M	
		J/A81		115	1500	8,30	M	
GETZ htb.	11/05-03/09	J/031		50	1100	7,10		
H-1/H300 Van, Minibus	02/08-	J/052		100	2300	13,52		-
H350 (3435, 3670)	01/16-	J/064		150	3500	17,17	M	-
i 10 I htb.	01/08-10/13	J/036		30	700	5,25	M	
i 20	06/09-08/14	J/040		50	1200	7,06		-
i 20	01/14-09/20	J/063		75	1200	6,98	M	
i 20 (excl. N-Line)	10/20-	J/086		85	1400	7,60	M	
		J/A86		85	1400	7,60	M	
i 30 I htb.	09/07-02/12	K/021		75	1500	8,30		-
i 30 I estate	03/08-07/10	J/035		75	1500	8,60		
i 30 II htb. (incl. Coupe)	01/12-12/16	J/047		80	1500	8,30	M	
i30 3/5D	01/17-	J/068		80	1500	8,40	M	
		J/A68		80	1500	8,40	M	
i30 Fastback	18-	J/066		85	1627	8,70	M	
		J/A66		85	1627	8,70	M	
i 30 II estate	06/12-05/17	K/044		75	1500	8,70	M	
i 40 saloon (excl. Adblue)	04/11-09/18	J/041		80	1800	9,92	M	
i 40 estate (excl. Adblue)	03/12-09/18	J/041		80	1800	9,92	M	
i 40 saloon (incl. AdBlue)	10/18-	J/082		85	1800	9,91	M	
		J/A82		85	1800	9,91	M	
ix 20 (JC)	11/10-01/19	J/042		75	1300	7,43	M	
ix 35	08/10-12/15	J/038		80	2200	10,14	M	
		J/A38		80	2200	10,14	M	
IONIQ 5	21-	J/085		110	1700	10,00	M	
		J/A85		110	1700	10,00	M	
IONIQ 6	10/22-	J/A89		120	1800	10,50	M	
KONA	17-	J/065		80	1250	7,41	M	-
		J/A65		80	1250	7,41	M	-
SANTA FE I	02/01-12/05	J/018		90	2300	11,52		-
SANTA FE II	03/06-08/12	J/020		90	2850	16,30		
SANTA FE III	09/12-06/18	J/051		100	2500	12,60	M	-
SANTA FE IV (TM, TMA) (incl. Hybrid, Ad-blue)	08/20-	J/084		159	2550	13,00	M	
		J/A84		159	2550	13,00	M	
SOLARIS	05/11-	J/061		75	1585	6,70	M	-
TUCSON I	08/04-03/10	K/020		80	2000	10,30		
TUCSON II	09/15-07/18	K/062		100	2200	10,90	M	-
		K/A62		100	2200	10,90	M	-















































 BRAND & MODEL	building year 	CAT NO.	 type of coupling	 vertical load	 max. towing weight	D-Value (kN)	electr. module	 bumper cut
TUCSON (excl. Adblue, N-line, GT line)	08/18-10/20	J/069		100	2200	11,00	M	-
		J/A69		100	2200	11,00	M	-
TUCSON (incl. Hybrid)	11/20-	J/083		120	2300	11,20	M	-
		J/A83		120	2300	11,20	M	-
ISUZU								
D-MAX	06/12-09/20	I/020		140	3500	15,97	M	-
D-MAX	10/20-	I/022		140	3500	17,17	M	-
IVECO								
DAILY UNIWERS.	01/82-04/99	I/004		250	3500	22,50		-
DAILY UNIWERS.	05/99-06/14	I/004		250	3500	22,50	M od 2005	-
DAILY VI 35S	07/14-	I/006		150	3500	23,00	M	-
DAILY VI 50	14-	I/007		200	3500	20,52	M	-
DAILY VI 35C Pick-up (double tyres)	07/14-	I/008		150	3500	23,00	M	-
DAILY VI (60 cm extended load-carrying body)	07/14-	I/009		150	3500	20,56	M	-
JEEP								
CHEROKEE (KJ)	09/01-12/07	J/026		140	3500	14,40		-
CHEROKEE (KK)	01/08-06/14	J/050		140	3500	14,37		
CHEROKEE (KL) (excl. Trailhawk)	07/14-08/19	J/071		150	2500	12,40	M	
CHEROKEE (KL)	09/19-	J/071		150	2500	12,40	M	
		J/A71		150	2500	12,40	M	
GRAND CHEROKEE II	03/99-05/05	J/025		140	3500	14,40		
GRAND CHEROKEE III	06/05-05/11	J/027		140	3500	15,16		
GRAND CHEROKEE IV (excl. SRT8)	04/11-21	J/029		175	3500	15,70	M	-
GRAND CHEROKEE L V (incl. Plug-in Hybrid)	05/21-	J/075		150	2800	14,60	M	
		J/A75		150	2800	14,60	M	
COMMANDER	05/06-05/11	J/027		140	3500	15,16		
COMPASS (MK) (excl. Rallye)	08/06-03/11	J/070		105	2000	10,11	M	
COMPASS II (MP)	01/17-	J/072		100	1535	8,70	M	
		J/A72		100	1535	8,70	M	
PATRIOT	02/07-03/11	J/070		105	2000	10,11		
RENEGADE (excl. Trailhawk)	09/14-	J/072		100	1535	8,70	M	
		J/A72		100	1535	8,70	M	
WRANGLER	04/07-10/17	J/028		350	3500	15,30	M	-
WRANGLER IV (JL)	08/18-	J/073		140	3500	15,30	M	-
		J/A73		140	3500	15,30	M	-
KIA								
CARNIVAL I	01/00-12/05	K/008		80	2000	8,66		
CARNIVAL II	07/06-01/16	K/048		85	2000	11,90	M	-
CEE'D htb	01/07-12/12	K/021		75	1500	8,30	M	-
CEE'D I estate	09/07-08/12	K/023		75	1600	8,85	M	-
CEE'D II htb. (excl. GT, GT-Line)	06/12-06/18	K/043		80	1500	8,30	M	-































































 BRAND & MODEL	building year 	CAT NO.	 type of coupling	 vertical load	 max. towing weight	D-Value (kN)	electr. module	 bumper cut
CEE'D II sw (excl. GT, GT-Line)	09/12-	K/044		75	1500	8,70	M	-
CEE'D III 5D	18-	K/069		85	1600	8,72	M	
		K/A69		85	1600	8,72	M	
CEE'D SW (estate)	18-	K/071		75	1500	8,41	M	
		K/A71		75	1500	8,41	M	
EV6 (A/R, EARTH, GT-LINE) (excl. GT)	08/21-	K/074		120	1800	10,60	M	-
		K/A74		120	1800	10,60	M	-
MAGENTIS	01-06	K/024		75	1700	10,00		
MAGENTIS	06-10	K/025		80	1700	9,10		
NIRO	09/16-05/19	K/066		100	1300	7,62	M	
		K/A66		100	1300	7,62	M	
NIRO (incl. HEV, PHEV)	04/22-	K/076		100	1350	8,20	M	
		K/A76		100	1350	8,20	M	
OPTIMA saloon (excl. Hybrid)	04/12-01/15	K/047		85	1800	9,90	M	
OPTIMA saloon	01/16-	K/063		85	1800	9,90	M	
OPTIMA estate	01/16-	K/063		85	1800	9,90	M	
PRO CEE'D I	02/09-05/12	K/021		75	1500	8,30	M	-
PRO CEE'D II (excl. GT)	06/12-06/18	K/043		80	1500	8,30	M	-
RIO III 4D	12-	K/068		75	1200	7,87	M	-
SOUL 5D (AM)	12/11-02/14	K/046		75	1400	7,99		-
SOUL 5D (DS)	03/14-	K/064		75	1400	7,99	M	-
SORENTO I (JC)	09/02-07/06	K/014		120	2800	13,22		
SORENTO I (JC)	07/06-10/09	K/022		140	3500	14,95		
SORENTO II (XM)	11/09-10/12	K/028		100	2500	12,30	M	
SORENTO II (XM)	11/12-01/15	J/051		100	2500	12,60	M	
SORENTO III (UM) (excl. Adblue)	01/15-08/20	K/045		100	2500	12,60	M	
SORENTO MQ4, MY (incl. Hybrid)	09/20-	K/073		100	2500	13,00	M	-
		K/A73		100	2500	13,00	M	-
SPORTAGE II (JE,KM)	01/05-08/10	K/020		80	2000	10,30		
SPORTAGE III (SL)	08/10-08/15	J/038		80	2200	10,14	M	-
		J/A38		80	2200	10,14	M	-
SPORTAGE IV	09/15-07/18	K/062		100	2200	10,90	M	-
		K/A62		100	2200	10,90	M	-
SPORTAGE IV (excl. Adblue)	07/18-08/21	J/069		100	2200	11,00	M	-
		J/A69		100	2200	11,00	M	-
SPORTAGE V (incl. Hybrid)	09/21-	J/083		120	2300	11,20	M	-
		J/A83		120	2300	11,20	M	-
STONIC	09/17-	K/067		75	1110	6,60	M	
		K/A67		75	1110	6,60	M	
X-CEED	09/19-	K/072		100	1600	8,60	M	
		K/A72		100	1600	8,60	M	

 BRAND & MODEL	building year 	CAT NO.	 type of coupling	 vertical load	 max. towing weight	D-Value (kN)	electr. module	 bumper cut
LANCIA								
ZETA	05/95-08/02	P/016		80	1800	9,70		
PHEDRA	09/02-11/10	F/020		80	1900	10,20		
LAND ROVER								
DEFENDER	01/98-	L/034		150	3500	17,17		-
DISCOVERY SPORT	15-	L/033		150	2500	12,85	M	
DISCOVERY V (type L462)	09/16-	L/035		195	3500	16,60	M	
EVOQUE	06/11-02/19	L/032		150	1800	10,00	M	-
		L/A32		150	1800	10,00	M	-
FREELANDER MK I	03/98-10/06	L/010		140	2000	10,00		-
FREELANDER MK II	10/06-10/14	L/031		150	2300	11,08	M	
RANGE ROVER SPORT	22-	L/036		200	3500	17,20	M	-
		L/A36		200	3500	17,20	M	-
LADA								
NIVA	01/76-	L/104		50	1500	7,70		-
GAZ SOBOL VAN	01/07-	L/011		75	1200	8,48		-
GAZ SOBOL pick-up	01/07-	L/110		75	1200	8,48		-
LEXUS								
NX	22-	T/080		114	1500	9,40	M	
		T/A80		114	1500	9,40	M	
LEXUS RX300, 350, 400	05/03-03/09	T/033		100	2400	11,80		
LEXUS RX350,RX450H	09-	T/044		85	2100	11,86		
MAN								
TGE furgon	11/16-	W/049		150	3500	17,17	M	-
MAZDA								
B2500 Pick-up 2WD/4WD	07/99-11/06	E/043		115	3000	15,01		-
BT 50 II Pick-up (excl. Pipe by bumper)	01/12-	E/050		225	3500	17,20	M	-
2 (DJ)	01/15-	X/033		70	1230	7,00	M	
		X/A33		70	1230	7,00	M	
3 htb. (BK) (excl. MPS 2,3l)	10/03-12/09	X/010		75	1765	8,71		-
3 saloon (BK) (excl. sport appearance pack)	10/03-12/09	X/010		75	1765	8,71		-
3 saloon	09-06/13	X/021		75	1800	9,31		-
3 htb. (BL)	01/09-12/14	X/010		75	1765	8,71		-
3 saloon	01/19-	X/034		80	1860	9,37	M	-
		X/A34		80	1860	9,37	M	-
3 htb.	01/19-	X/035		80	1860	9,37	M	-
		X/A35		80	1860	9,37	M	-
5 I (CR19)	02/05-09/10	X/019		75	1600	9,30	M	
5 II (CW)	01/11-	X/019		75	1600	9,30	M	
6 htb. saloon (GG) (excl. MPS 2,3l)	01/03-01/08	X/011		75	1800	8,95		
6 estate (GY)	01/03-01/08	X/013		75	1800	8,95		





 BRAND & MODEL	building year 	CAT NO.	 type of coupling	 vertical load	 max. towing weight	D-Value (kN)	electr. module	 bumper cut
6 II saloon (GH)	03/08-01/13	X/018		100	1600	10,01		
6 II estate (GH)	05/08-01/13	X/018		100	1600	10,01		
6 II htb. (GH)	03/08-01/13	X/018		100	1600	10,01		
6 saloon (GJ, GL)	02/13-	X/025		75	1800	10,10	M	
		X/A25		75	1800	10,10	M	
6 estate (GJ, GL)	02/13-	X/025		75	1800	10,10	M	
		X/A25		75	1800	10,10	M	
CX-3 (DK)	01/15-	X/030		75	1800	8,88	M	
		X/A30		75	1800	8,88	M	
CX-30	01/19-	X/036		95	1583	8,80	M	
		X/A36		95	1583	8,80	M	
CX-5 I (KE,GH)	11/11-01/17	X/023		88	2300	10,83	M	-
CX-5 II (KF) (excl. Adblue)	02/17-	X/031		100	2100	10,40	M	-
		X/A31		100	2100	10,40	M	-
CX-7 (ER)	07-12	X/020		75	1700	10,00	M	
CX-9	07-	X/A22		85	1900	11,30	M	-
MPV. LW	04-09	X/014		85	2000	10,80		-
PREMACY VAN, 5 doors	11/99-06/05	X/016		75	1600	8,40		
MERCEDES								
124 saloon (W124)	01/85-06/95	M/002		75	1900	10,00		-
124 estate(S124)	01/86-06/96	M/002		75	1900	10,00		-
124 coupe (C124)	01/85-06/95	M/002		75	1900	10,00		-
124 cabrio(A124)	01/85-06/95	M/002		75	1900	10,00		-
A-CLASS (W168) (excl. A210 evo)	07/97-08/05	M/017		50	1000	6,11		-
A-CLASS (W169)	10/04-08/12	M/025		70	1500	8,65	M	
		M/A25		70	1500	8,65	M	
A-CLASS (W176) (excl. AMG,Urban-Line, Style Line)	09/12-06/15	M/046		100	1600	9,35	M	
B-CLASS (W245)	06/05-10/11	M/025		70	1500	8,65	M	
		M/A25		70	1500	8,65	M	
B-CLASS (W246) (excl. AMG,Urban-Line, Style-Line)	11/11-	M/046		100	1600	9,35	M	-
C-CLASS (W202) (excl. AMG, 430)	06/93-05/00	M/011		75	1700	8,72	M	-
C-CLASS (S202) (excl. AMG, 430)	06/96-03/01	M/011		75	1700	8,72		-
C-CLASS (W203) (excl. AMG)	06/00-02/07	M/032		75	1700	10,00	M	-
		M/A32		75	1700	10,00	M	-
C-CLASS (S203) (excl. AMG)	04/01-08/07	M/032		75	1700	10,00	M	-
		M/A32		75	1700	10,00	M	-
C-CLASS (W204) (excl. AMG)	03/07-02/14	M/034		100	2300	10,20	M	
		M/A34		100	1800	10,20	M	



























































 BRAND & MODEL	building year 	CAT NO.	 type of coupling	 vertical load	 max. towing weight	D-Value (kN)	electr. module	 bumper cut
C-CLASS (S204) (excl. AMG)	03/07-05/14	M/034		100	2300	10,20	M	
		M/A34		100	1800	10,20	M	
C-CLASS (W205) (excl. AMG)	12/13-02/21	M/047		75	1900	10,22	M	-
		M/A47		75	1900	10,22	M	-
C-CLASS (W206) (excl. AMG)	03/21-	M/060		100	2100	11,00	M	
		M/A60		100	2100	11,00	M	
C-CLASS (S206) (excl. AMG)	03/21-	M/060		100	2100	11,00	M	
		M/A60		100	2100	11,00	M	
CITAN (4321mm, 4705mm) (excl. Adblue)	10/12-04/13	R/042		75	1350	7,62	M	-
CLA (C117) (excl. AMG)	04/13-03/19	M/049		100	1800	9,52	M	-
		M/A49		100	1800	9,52	M	-
CLA (C118)	19-	M/057		120	2100	10,70	M	
		M/A57		120	2100	10,70	M	
E-CLASS (W210) (excl. AMG)	06/95-03/03	M/019		100	2100	11,50		-
E-CLASS (S210) estate (excl. AMG)	05/96-02/03	M/023		85	2100	11,02		-
E-CLASS (W211) (excl. AMG)	03/02-03/09	M/027		75	2200	10,70	M	-
		M/A27		75	2200	10,70	M	-
E-CLASS (S211) (excl. AMG)	03/03-10/09	M/041		130	2100	11,40	M	-
		M/A41		130	2100	11,40	M	-
E-CLASS (W212) (excl. AMG)	01/09-12/16	M/048		88	2200	11,39	M	-
		M/A48		88	2200	11,39	M	-
E-CLASS (S212) (excl. AMG)	09/09-12/16	M/044		88	2100	11,64	M	-
		M/A44		88	2100	11,64	M	-
E-CLASS(W213) (excl. AMG)	16-	M/056		84	2434	11,95	M	
		M/A56		84	2434	11,95	M	
GL (X164)	12/05-10/12	M/042		135	3500	16,54	M	-
		M/A42		135	3500	16,54	M	-
GL (X166)(excl. AMG)	11/12-10/15	M/042		135	3500	16,54	M	-
		M/A42		135	3500	16,54	M	-
GLA (X156) (excl. AMG)	03/14-02/19	M/049		100	1800	9,52	M	-
		M/A49		100	1800	9,52	M	-
GLC (X253) (incl. AMG, Coupe)	09/15-03/19	M/A53		100	2730	13,32	M	
GLC (X253) (incl. AMG, Coupe)	03/19-06/22	M/A59		100	2730	13,32	M	
GLE Coupe (c292) (incl. AMG) (excl. 6.3 AMG)	07/15-	M/043		135	3500	16,54	M	
		M/A43		135	3500	16,54	M	
GLE (W167)	10/18-	M/054		140	3500	16,55	M	
		M/A54		140	3500	16,55	M	
GLK (X204) (excl. Sport pakiet)	07/09-19/15	M/045		100	2400	12,01	M	-
		M/A45		100	2400	12,01	M	-
GLS (X166)(excl. AMG)	11/15-04/19	M/042		135	3500	16,54	M	-
		M/A42		135	3500	16,54	M	-







 BRAND & MODEL	building year 	CAT NO.	 type of coupling	 vertical load	 max. towing weight	D-Value (kN)	electr. module	 bumper cut
ML (W164) (excl. AMG)	07/05-10/11	M/043		135	3500	16,54	M	-
		M/A43		135	3500	16,54	M	-
S-CLASS (W222) (incl. AMG line)	01/14-	M/055		110	2200	12,00	M	
		M/A55		110	2200	12,00	M	
SPRINTER BOX, BUS (WB. 3,55/4,025m)	02/95-06	M/007		120	2800	15,85		-
SPRINTER BOX, BUS (WB. 3,55/4,025m) with footboard	02/95-05/06	M/012		120	2800	16,05		-
SPRINTER pick up (single tyres)	02/95-05/06	M/015		100	2800	15,26		-
SPRINTER BOX, BUS (WB. 3665/4,325) (single and double tyres)	06/06-05/18	M/021		140	3500	20,20	M	-
SPRINTER pick up (5T)(double tyres)	04/06-05/18	M/024		140	3500	20,20	M	-
SPRINTER BOX, BUS (3,665/4,325m) (single tyres) with footboard	04/06-05/18	M/031		100	2800	15,24	M	-
SPRINTER pick up (3,665/4,325m)(single tyres)	06/06-05/18	M/021		140	3500	20,20	M	-
SPRINTER BOX, BUS (WB. 3,665/3,924/4,325m) (single/double tyres) (FWD/RWD) (without footboard)	05/18-	M/058		150	3500	20,30	M	-
SPRINTER BOX, BUS (3,665/4,325m) (single/double tyres)(RWD) with footboard	06/18-	M/031		100	2800	15,24	M	-
VANEO (W414)	02/02-07/05	M/026		50	1200	7,40	M	-
VIANO (excl. X-clusive, PDC)	08/03-08/14	M/020		100	2500	13,25	M	
VITO (excl. PDC)	02/96-07/03	M/008		75	2000	11,70		
VITO II (excl. X-clusive, PDC)	09/03-08/14	M/020		100	2500	13,25	M	
VITO III (W447)	05/14-	M/050		100	2500	13,77	M	
		M/A50		100	2500	13,77	M	
X-CLASS pick-up (excl.King Cab)	09/17-	N/054		140	3519	16,83	M	-
MG								
HS (PHEV)	20-	MG/001		90	1500	9,30	M	
		MG/A01		90	1500	9,30	M	
MARVEL	12/21-	MG/002		85	1000	7,00	M	-
		MG/A02		85	1000	7,00	M	-
MITSUBISHI								
ASX	10 -	Y/028		70	1500	8,96		-
		Y/A28		70	1500	8,17		-
CARISMA htb. (DA)	08/95-06/06	Y/001		75	1500	7,91		-
CARISMA saloon (DA)	08/95-06/06	Y/001		75	1500	7,91		-
L-200 pick-up 4WD, single cab, double cab, club cab (short version)	05/06-12/15	Y/011		115	2700	14,10		-
L-200 pick-up 4WD, single cab, double cab, club cab (long version)	10/09-	Y/025		115	2700	14,10		-
LANCER 4 doors	04-08	Y/014		75	1500	7,20		-
OUTLANDER I (CU)	04/03-03/07	Y/021		75	1500	8,66		-

 BRAND & MODEL	building year 	CAT NO.	 type of coupling	 vertical load	 max. towing weight	D-Value (kN)	electr. module	 bumper cut
OUTLANDER II (CW)	04/07-09/12	Y/024		100	2000	11,00	M	
		Y/A24		100	2000	11,00	M	
OUTLANDER III (GG/GF)	09/12-07/21	Y/029		100	2000	11,00	M	-
		Y/A29		100	2000	11,00	M	-
OUTLANDER IV	08/21-	Y/035		100	2000	11,00	M	
		Y/A35		100	2000	11,00	M	
PAJERO III (5doors) V70	05/00-12/06	Y/013		120	3000	15,20		-
PAJERO IV (5doors) (V80, V90)	02/07-	Y/026		135	3300	15,81		-
PAJERO SPORT (K90)	11/98-06/08	Y/015		100	2800	13,60		-
SPACE STAR	98-06	Y/008		75	1400	7,63		
TRITON	01/20-	Y/036		160	3500	16,25	M	-
NISSAN								
ALMERA II htb. (N16)	03/00-12/06	N/014		75	1600	8,09		
ALMERA TINO (V10)	08/00-12/06	N/027		75	1650	8,40		
INTERSTAR (BUS,BOX,Pick-up) (excl. dual tyres, maxi)	05/02-03/10	R/009		100	2300	13,62		-
JUKE I (excl. 4WD, Nismo)	10/10-08/19	N/052		75	1500	8,50	M	
JUKE II (F16)	09/19-	N/057		75	1680	8,70	M	
		N/A57		75	1680	8,70	M	
MICRA htb. (K12)	02/03-12/10	N/031		75	1300	6,78		
MURANO I (Z50)	03/05-07/08	N/035		80	1535	9,18		
MURANO (Z 51)	08/08-	N/039		100	1585	10,90		
NAVARRA NP300 (footboard bumper, double cab) (D40)	12/04-12/15	N/025		120	3000	14,50		-
NAVARA (D23)	07/14-	N/054		140	3519	16,83		-
NAVARA (D40)	11/15-	N/054		140	3519	16,83		-
NV300 (L1,L2)	09/16-	R/066		100	2100	12,21		-
NV400	07/10-	R/051		100	2500	14,31	M	-
NV400 L2, L3, L4 Maxi, VAN, single/double wheels, FWD/RWD, with step, without step	03/10-12/21	R/074		120	3000	15,85	M	-
QASHQAI (J10, NJ10) (incl. 7 seats)	11/06-04/14	N/032		75	1600	8,50		
		N/A32		75	1600	8,50		
QASHQAI (J11) (incl. 7 seats)	04/14-10/18	N/032		75	1600	8,50	M	-
		N/A32		75	1600	8,50	M	-
QASHQAI (J11) facelifting (incl. Adblue)	11/18-03/21	N/056		120	2000	10,20	M	
		N/A56		120	2000	10,20	M	
QASHQAI III (J12)	04/21-	N/058		120	2100	10,40	M	-
		N/A58		120	2100	10,40	M	-
PATROL Y61	01/98-09/04	N/023		140	3500	16,30		-
PATROL Y61	10/04-09/09	N/023		140	3500	16,30		-
PICK-UP D22 4WD	01/02-	N/017		110	3000	13,00		-
PRIMASTAR	09/02-08/14	R/024		80	2000	11,70		-
PRIMERA estate (W11)	04/98-03/02	N/018		75	1700	9,00		

 BRAND & MODEL	building year 	CAT NO.	 type of coupling	 vertical load	 max. towing weight	D-Value (kN)	electr. module	 bumper cut
PRIMERA P11 saloon	09/99-02/02	N/016		75	1700	8,40		
PRIMERA P11 htb.	09/99-02/02	N/016		75	1700	8,40		
PRIMERA saloon (P12)	03/02-07/07	N/024		75	1500	9,40		
PRIMERA estate (W12)	09/01-05/07	N/034		75	1850	9,40		
TERRANO II (R20) (excl. pick up)	02/93-02/05	N/021		100	2600	12,75		-
X-TRAIL (T30)	03/03-12/07	N/022		100	2300	11,20		
X-TRAIL (T31) (excl. Parktronic)	03/07-06/14	N/036		100	2200	10,60		
X-TRAIL (T32) (excl. Adblue)	07/14-07/17	N/053		110	2200	11,10	M	-
		N/A53		110	2200	11,10	M	-
X-TRAIL (T32)	06/17-08/22	R/069		100	2000	10,50	M	
		R/A69		100	2000	10,50	M	
X-TRAIL (T33)	09/22-	N/059		144	2288	11,80	M	
		N/A59		144	2288	11,80	M	
OPEL								
ASTRA F htb.	09/91-12/01	O/003		75	1500	8,10		
ASTRA F saloon	09/91-12/02	O/004		75	1500	8,10		-
ASTRA G saloon	03/98-12/09	O/007		75	1500	8,50		-
ASTRA G htb.	03/98-12/09	O/007		75	1500	8,50		-
ASTRA G estate	03/98-12/09	O/008		75	1500	8,50		-
ASTRA H htb. (incl.GTC) (excl.OPC, CNG)	03/04-01/14	O/030		75	1650	8,97	M	-
		O/A30		75	1650	8,97	M	-
ASTRA III H estate	09/04-12/14	O/031		75	1650	8,97	M	-
		O/A31		75	1650	8,97	M	-
ASTRA J htb.	09/09-05/15	O/039		75	1500	9,60	M	
		O/A39		75	1500	8,29	M	
ASTRA J estate SPORTS TOURER (excl. OPC-LINE)	10/10-10/15	O/040		75	1800	9,60	M	-
		O/A40		75	1800	9,60	M	-
ASTRA K htb.	06/15-	O/047		75	1920	10,00	M	
		O/A47		75	1920	10,00	M	
ASTRA K estate Sport Turier	11/15-	O/046		75	2100	10,00	M	-
		O/A46		75	2100	10,00	M	-
CORSA B htb.	03/93-09/00	O/010		50	1100	5,90		
CORSA C htb.	10/00-08/06	O/024		50	1200	7,10		
CORSA D htb. (excl. OPC, GSI)	09/06-11/14	O/033		55	1350	7,66	M	
CORSA E htb. (excl. OPC, GSI)	12/14-06/19	O/033		55	1350	7,66	M	
CORSA F	19-	O/A50		80	1300	7,50	M	
COMBO C (excl. CNG)	09/01-12/11	O/023		50	1200	7,49		
COMBO D (excl. CNG)	02/12-06/18	F/031		65	1620	9,79	M	
COMBO E (L1 - 4403)	03/18-	C/029		80	1600	8,69	M	-
		C/A29		80	1600	8,69	M	-
COMBO E (L2 - 4753)	06/18-	C/045		78	1600	9,43	M	-
		C/A45		75	1600	9,43	M	-



































































 BRAND & MODEL	building year 	CAT NO.	 type of coupling	 vertical load	 max. towing weight	D-Value (kN)	electr. module	 bumper cut
FRONTERA	10/98-01/06	O/036		112	2800	12,90		-
GRANDLAND X (excl. hybrid, cng, lpg)	06/17-	P/044		100	2000	10,10	M	
		P/A44		100	2000	10,10	M	
GRANDLAND X Plugin Hybrid	06/19-	P/049		80	1300	8,25	M	
		P/A49		80	1300	8,25	M	
INSIGNIA saloon (excl. OPC)	07/08-05/17	O/038		85	2000	11,00	M	
		O/A38		85	2000	11,00	M	
INSIGNIA htb. (excl. OPC)	07/08-05/17	O/038		85	2000	11,00	M	
		O/A38		85	2000	11,00	M	
INSIGNIA estate Sport Tourer (excl. OPC)	07/08-05/17	O/038		85	2000	11,00	M	
		O/A38		85	2000	11,00	M	
INSIGNIA Grand Sport (excl. OPC, GSI)	06/17-	O/045		90	2200	11,10	M	
		O/A45		90	2200	11,10	M	
INSIGNIA kombi SW	06/17-	O/049		90	2334	11,60	M	
		O/A49		90	2334	11,60	M	
MERIVA (excl. OPC)	04/03-04/10	O/035		60	1360	7,60	M od 2005	
MERIVA B (excl. 1,3 CDTi Eco Flex 70KW)	06/10-03/17	O/041		75	1500	8,96	M	
		O/A41		75	1500	8,96	M	
MOKKA (excl. OPC)	11/12-	O/044		75	1500	8,75	M	
		O/A44		75	1500	8,75	M	
MOVANO furgon, minibus (excl. double tyres, maxi)	01/98-03/10	R/009		100	2300	13,62		-
MOVANO van (FWD)	04/10-	R/046		100	3000	14,31	M	-
MOVANO van (RWD)	07/10-	R/051		100	2500	14,31	M	-
MOVANO L2, L3, L4 Maxi, VAN, single/double wheels, FWD/RWD, with step, without step	03/10-12/21	R/074		120	3000	15,85	M	-
MOVANO pick-up (incl. double tyres)	08/10-	R/052		100	2500	14,31	M	-
OMEGA A saloon	09/86-03/94	O/028		75	2100	10,90		-
OMEGA B saloon	03/94-07/03	O/028		75	2100	10,90		-
SINTRA	01/96-12/00	O/029		75	1820	10,80		-
VECTRA B saloon	10/95-06/02	O/018		75	1700	9,30		-
VECTRA B estate	11/96-06/03	O/018		75	1700	9,30		-
VECTRA B htb.	10/95-06/02	O/018		75	1700	9,30		-
VECTRA C saloon	06/02-08/08	O/026		80	1950	10,72	M	-
		O/A26		80	1950	10,72	M	-
VECTRA C htb.	06/02-08/08	O/026		80	1950	10,72	M	-
		O/A26		80	1950	10,72	M	-
VECTRA C estate	12/02-08/08	O/027		85	2000	10,72	M	-
		O/A27		85	2000	10,72	M	
ZAFIRAA	04/99-06/05	O/019		75	1600	8,91		-

 BRAND & MODEL	building year 	CAT NO.	 type of coupling	 vertical load	 max. towing weight	D-Value (kN)	electr. module	 bumper cut
ZAFIRA B	07/05-12/11	O/034		75	1650	9,60	M	
		O/A34		75	1650	9,60	M	
ZAFIRA C Tourer (excl. CNG)	01/12-	O/042		75	1500	9,90	M	
VIVARO	01-07/14	R/024		80	2000	11,70		-
VIVARO (L1,L2)	06/14-	R/066		100	2100	12,21	M	-
PEUGEOT								
206 (excl. Sport XS, GTI, Quicksilver)	10/98-03/03	P/003		50	1100	6,39		
206	04/03-12/09	P/023		50	1100	6,39		-
206 +	01/09-12/12	P/023		50	1100	6,39		-
206 estate	06/02-12/06	P/022		50	1100	6,30		-
207 htb.	06/06-06/12	P/031		50	1150	6,70	M	
		P/A31		50	1150	6,70	M	
207 estate (excl. Outdoor, RC)	06/07-06/13	P/034		50	1150	6,88	M	
		P/A34		50	1150	6,88	M	
208 htb.	04/12-05/19	P/040		55	1300	7,20	M	-
		P/A40		55	1300	7,20	M	-
208 htb.	19-	O/A50		80	1300	7,50	M	
307 htb.	05/01-09/07	P/021		60	1500	8,06	M od 2005	-
307 estate	12/01-03/08	P/024		70	1700	9,10	M od 2005	-
308 htb. (excl. GTI, sport bumper)	10/07-08/13	P/021		60	1500	8,06	M	-
308 estate	03/08-02/14	P/035		77	1700	9,48	M	-
308 htb. (excl. GTI, GT-Line, sport bumper)	09/13-	C/039		70	1750	9,56	M	-
308 estate (excl. GTI, GT-Line, sport bumper)	03/14-	C/039		70	1750	9,56	M	-
406 saloon	09/95-03/04	P/010		75	1700	8,60		-
406 estate	12/96-05/04	P/014		75	1700	8,65		-
407 saloon	04/04-06/08	P/032		75	1600	9,55	M	-
407 estate	06/04-02/11	P/033		65	1600	9,19	M	-
508 saloon (excl. GT)	03/11-08/18	P/039		80	2250	10,80	M	
		P/A39		80	2250	10,80	M	
508 estate (excl. GT, RHX. 2.2l Hdi)	03/11-08/18	P/038		75	1900	10,19	M	-
		P/A38		75	1900	10,19	M	
508 II liftback (incl. Adblue)	19-	P/048		100	2000	10,30	M	
		P/A48		100	2000	10,30	M	
508 II SW estate	19-	P/047		90	2000	10,50	M	
		P/A47		90	2000	10,50	M	
1007	10/05-01/10	C/016		50	1100	6,10		-
2008	04/13-07/19	P/043		60	1300	7,24	M	-
		P/A43		60	1300	7,24	M	-





































































 BRAND & MODEL	building year 	CAT NO.	 type of coupling	 vertical load	 max. towing weight	D-Value (kN)	electr. module	 bumper cut
3008 (excl. Hybrid)	06/09-04/16	P/036		75	1600	9,20	M	-
		P/A36		75	1600	9,20	M	-
3008 II (excl. Hybrid)	05/16-	P/044		100	2000	10,10	M	
		P/A44		100	2000	10,10	M	
3008 II Hybrid	10/19-	P/049		80	1300	8,25	M	
		P/A49		80	1300	8,25	M	
4007	09/07-08/12	Y/024		100	2000	11,00		
		Y/A24		100	2000	11,00		
4008	12-	Y/028		70	1500	8,96		-
		Y/A28		70	1500	8,17		-
5008	10/09 - 04/17	P/037		100	1700	9,70	M	-
		P/A37		100	1700	9,70	M	-
5008 II (excl. version with spare wheel)	05/17-	P/045		100	2000	10,10	M	
		P/A45		100	2000	10,10	M	
806	06/94-08/02	P/016		80	1800	9,70		
807	09/02-06/11	F/020		80	1900	10,20	M	
EXPERT I	12/94-12/06	P/016		80	1800	9,70		
EXPERT II	02/07-01/16	F/023		80	2000	11,93	M	
		F/A23		80	2000	11,93	M	
EXPERT III	01/16-	C/042		100	2500	13,60	M	-
		C/A42		100	2500	13,60	M	-
BIPPER	02/08-	F/027		60	1100	6,83	M	
BOXER	05/94-06/06	C/005		110	2200	12,49		-
BOXER III VAN (L1, L2, L3)	07/06-	C/018		150	3500	17,17	M	
BOXER III VAN (L4)	04/06-	C/030		120	3100	16,13	M	
BOXER III Pick-up (L1, L2, L3)	04/06-	C/025		120	3100	15,09	M	-
BOXER III Pick-up (L1, L2, L3) (extended load-carrying body)	08/06-	C/047		100	3500	17,17	M	-
PARTNER I	11/96-04/08	C/012		70	1100	7,00		-
PARTNER II (L1 - 4380)	04/08-02/18	C/029		80	1600	8,69	M	-
		C/A29		80	1600	8,69	M	-
PARTNER II (L2 - 4680)	05/08-05/18	C/036		65	1600	8,69	M	-
		C/A36		65	1600	8,69	M	-
PARTNER III (L1 - 4403)	03/18-	C/029		80	1600	8,69	M	-
		C/A29		80	1600	8,69	M	-
PARTNER III (L2 - 4753)	06/18-	C/045		75	1600	9,43	M	-
		C/A45		75	1600	9,43	M	-
RIFTER (L1 - 4403)	03/18-	C/029		80	1600	8,69	M	-
		C/A29		80	1600	8,69	M	-
RIFTER (L2 - 4753)	06/18-	C/045		75	1600	9,43	M	-
		C/A45		75	1600	9,43	M	-



 BRAND & MODEL	building year 	CAT NO.	 type of coupling	 vertical load	 max. towing weight	D-Value (kN)	electr. module	 bumper cut
RENAULT								
ALASKAN Pick-up	10/16-	N/054		140	3519	16,83	M	-
ARKANA	21-	R/077		75	1650	8,80	M	
		R/A77		75	1650	8,80	M	
CAPTUR	05/13-12/19	R/057		75	1200	7,20	M	-
CAPTUR II	01/20-	R/076		106	1500	9,10	M	
		R/A76		106	1500	9,10	M	
CLIO II (excl. Sport V6)	03/98-12/04	R/016		75	1200	6,67		-
CLIO III htb. (excl. 1.6l 16V 94kW)	09/05-12/12	R/033		75	1200	7,00		
CLIO III Grandtour estate	02/08-02/13	R/047		75	1200	7,69		-
CLIO IV htb. (excl. RS, GT, GT-Line)	11/12-05/19	R/054		75	1200	7,06	M	
CLIO IV Grandtour estate (excl. GT)	03/13-	R/055		75	1200	7,69	M	-
CLIO V	19-	R/075		80	1300	7,00	M	
		R/A75		80	1300	7,00	M	
ESPACE J66/JE	96-10/02	R/019		85	1900	10,61		
ESPACE	10/02-03/15	R/034		80	2000	11,29		-
		R/A34		80	2000	11,29		-
ESPACE	04/15-	R/061		80	2000	10,84	M	-
GRAND ESPACE J66/JE	11/96-10/02	R/019		85	2000	10,61		-
GRAND ESPACE	10/02-03/15	R/035		80	2000	11,29		
		R/A35		80	2000	11,29		
FLUENCE	11/09-	R/058		75	1300	7,50	M	
KADJAR (excl. Adblue)	06/15-	R/059		75	2000	12,81	M	-
KANGOO (excl. Maxi)	01/97-02/08	R/006		75	1350	7,73		-
KANGOO II (excl. Adblue)	03/08-	R/042		75	1350	7,62	M	-
KOLEOS	09/08-02/17	R/041		100	2000	10,50		-
		R/A41		100	2000	10,50		-
KOLEOS II (incl. Adblue)	03/17-	R/069		100	2000	10,50	M	
		R/A69		100	2000	10,50	M	
LAGUNA I htb.	11/93-12/00	R/007		75	1650	9,76		-
LAGUNA I estate	08/95-08/00	R/008		75	1850	9,30		-
LAGUNA II htb.	03/01-08/07	R/020		75	1600	8,50		-
LAGUNA II estate	03/01-08/07	R/018		75	1500	8,50		-
LAGUNA III htb. (excl. GT)	10/07-09/15	R/043		75	1500	8,80	M	-
		R/A43		75	1500	8,80	M	-
LAGUNA III estate (excl. GT)	10/07-09/15	R/037		75	1500	9,76	M	-
		R/A37		75	1500	9,76	M	-
LATITUDE	10/10-	R/060		75	1500	8,75	M	-
		R/A60		75	1500	8,75	M	-
MASTER van, pick-up (excl. double tyres, maxi)	01/98-03/10	R/009		100	2300	13,62		-

 BRAND & MODEL	building year 	CAT NO.	 type of coupling	 vertical load	 max. towing weight	D-Value (kN)	electr. module	 bumper cut	
MASTER van (FWD)	04/10-	R/046		100	3000	14,31	M	-	
MASTER van (RWD)	07/10-	R/051		100	2500	14,31	M	-	
MASTER L2, L3, L4 Maxi, VAN, single/double wheels, FWD/RWD, with step, without step	03/10-	R/074		120	3000	15,85	M	-	
MASTER pick-up (FWD, RWD, single tyres)	08/10-	R/052		100	2500	14,31	M	-	
MEGANE I htb.	04/99-10/02	R/031		75	1350	6,20		-	
MEGANE I htb.	01/96-03/99	R/010		75	1350	7,39		-	
MEGANE II saloon	09/03-06/09	R/028		75	1350	7,73		-	
MEGANE II estate	09/03-06/09	R/028		75	1350	7,73		-	
MEGANE II htb. (excl. Sport)	11/02-10/08	R/030		75	1350	7,56			
MEGANE III estate	11/08-08/15	R/048		75	1500	8,41	M	-	
MEGANE III htb. (excl. RS, GT, GT-Line)	03/09-01/16	R/045		75	1300	7,44	M	-	
		R/A45		75	1300	7,44	M	-	
MEGANE IV grand coupe (4D)	10/16-	R/068		85	2145	10,10	M	-	
		R/A68		85	2145	10,10	M	-	
MEGANE IV estate Grandtour	09/16-	R/070		80	2145	10,10	M		
		R/A70		80	2145	10,10	M		
MEGANE IV (5D)	02/16-	R/071		75	2170	10,00	M		
		R/A71		75	2170	10,00	M		
SCENIC II (excl. Crossroad, 4WD)	07/03-04/09	R/029		75	1350	8,02			
		R/A29		75	1350	8,02			
GRAND SCENIC II (excl. Crossroad, 4WD)	07/03-04/09	R/029		75	1350	8,02			
		R/A29		75	1350	8,02			
SCENIC III	07/09-08/16	R/049		75	1400	8,24	M		
		R/A49		75	1400	8,24	M		
GRAND SCENIC III	04/09-08/16	R/050		75	1400	8,24	M		
		R/A50		75	1400	8,24	M		
SCENIC IV	01/17-	R/064		75	1948	10,50	M		
		R/A64		75	1948	10,50	M		
GRAND SCENIC IV	01/17-	R/064		75	1948	10,50	M		
		R/A64		75	1948	10,50	M		
TALISMAN saloon	01/15-	R/062		80	2000	10,10	M		
		R/A62		80	2000	10,10	M		
TALISMAN estate	01/16-	R/063		80	2000	10,10	M		
		R/A63		80	2000	10,10	M		
THALIA	01/99-07/08	R/026		75	1150	6,70		-	
THALIA	08/08-	R/026		75	1150	6,70		-	
TRAFIC	07/01-08/14	R/024		80	2000	11,70		-	
TRAFIC	09/14-	R/066		100	2100	12,21	M	-	
SEAT									
ALTEA	05/04-	S/013		75	1600	8,91	M		
ALTEA XL	11/06-	S/013		75	1600	8,91	M		

































































 BRAND & MODEL	building year 	CAT NO.	 type of coupling	 vertical load	 max. towing weight	D-Value (kN)	electr. module	 bumper cut	
ARONA HB	07/17-	S/018		55	1200	7,10	M	-	
		S/A18		55	1210	7,10	M	-	
ALHAMBRA	12/95-04/00	E/010		85	2100	11,20		-	
ALHAMBRA	05/00-09/10	E/030		100	2100	12,50		-	
ALHAMBRA	07/10-06/12	W/038		100	2500	12,50	M		
CORDOBA (CLX, GLX, GTI, SX)	02/96-12/02	S/002		50	1200	6,70			
CORDOBA VARIO estate	10/99-12/02	S/002		50	1200	6,70			
CORDOBA saloon	01/03-11/09	S/011		50	1200	6,96			
EXEO; EXEO ST	09-13	S/014		80	2000	10,71	M	-	
		S/A14		80	2000	10,71	M	-	
IBIZA	09/99-04/02	S/002		50	1200	6,70			
IBIZA (excl. FR, Cupra)	05/02-08/08	W/022		50	1200	6,90			
IBIZA estate	06/10-	S/015		75	1200	6,95	M	-	
		S/A15		75	1200	6,95	M	-	
IBIZA htb. (excl. Cupra)	09/08-05/17	S/015		75	1200	6,95	M	-	
		S/A15		75	1200	6,95	M	-	
IBIZA (excl. GTI, CNG)	01/17-	S/017		75	1200	6,92	M	-	
		S/A17		75	1200	6,92	M	-	
LEON I	11/99-08/05	W/018		75	1650	9,06			
LEON II	09/05-10/12	S/013		75	1600	8,91	M		
		S/A13		75	1600	8,91	M		
LEON III htb. (incl. SC, FR)	11/12-02/20	Z/016		100	1800	9,50	M		
LEON III estate (incl. FR, X-Perience)	10/13-02/20	Z/016		100	1800	9,50	M		
LEON IV htb.	04/20-	Z/016		100	1800	9,50	M		
MII	12/11-	Z/019		50	850	5,15	M		
		Z/A19		50	850	5,15	M		
TARRACO	07/17-	Z/023		140	2500	12,62	M		
		Z/A23		140	2500	12,62	M		
TOLEDO STELLA	04/99-05	S/009		75	1600	8,70			
TOLEDO	01/05-12/09	S/013		75	1600	8,91	M		
		S/A13		75	1600	8,91	M		
TOLEDO IV htb. (excl. Scoutline)	03/13-	Z/017		75	1500	8,00	M		
TOLEDO IV saloon	03/13-	Z/018		75	1500	8,00	M		
SKODA									
CITIGO	12/11-	Z/019		50	850	5,15	M		
		Z/A19		50	850	5,15	M		
ENYAQ iV (5AC, 5AZ)	10/20-	Z/034		85	1500	9,60	M		
		Z/034		85	1500	9,60	M		
FABIA I htb. (excl. RS)	12/99-03/07	Z/006		50	1200	6,50			
FABIA I saloon (excl. RS)	07/01-12/07	Z/007		50	1200	7,00			
FABIA I estate (excl. RS)	11/00-12/07	Z/007		50	1200	7,00			





































































 BRAND & MODEL	building year 	CAT NO.	 type of coupling	 vertical load	 max. towing weight	D-Value (kN)	electr. module	 bumper cut
FABIA II estate (excl. RS)	10/07-10/14	Z/025		85	1415	7,50	M ₋₁₀	
		Z/A25		85	1415	7,50	M ₋₁₀	
FABIA II htb. (excl. RS)	04/07-10/14	Z/025		85	1415	7,50	M ₋₁₀	
		Z/A25		85	1415	7,50	M ₋₁₀	
FABIA III htb	11/14-10/18	Z/025		85	1415	7,50	M	
		Z/A25		85	1415	7,50	M	
FABIA III estate	11/14-10/18	Z/025		85	1415	7,50	M	
		Z/A25		85	1415	7,50	M	
FABIA III estate (facelift)	08/18-	Z/026		85	1415	7,50	M	
		Z/A26		85	1415	7,50	M	
FABIA IV htb.	06/21-	Z/033		75	1200	7,20	M	
		Z/A33		75	1200	7,20	M	
KAMIQ	08/19-	Z/032		90	1500	8,30	M	
		Z/A32		90	1500	8,30	M	
KAROQ	07/17-	Z/024		90	2000	10,80	M	
		Z/A24		90	2000	10,80	M	
KODIAQ (excl. Scout, RS)	10/16-	Z/023		140	2500	12,62	M	
		Z/A23		140	2500	12,62	M	
OCTAVIA htb.	12/96-12/10	Z/005		75	1650	8,91		
OCTAVIA estate	98-10	Z/005		75	1650	8,91		
OCTAVIA II htb.	06/04-01/13	Z/011		75	1700	9,30	M	
		Z/A11		75	1700	9,30	M	
OCTAVIA II estate	01/05-01/13	Z/011		75	1700	9,30	M	
		Z/A11		75	1700	9,30	M	
OCTAVIA III htb. (incl. RS)	02/13-12/19	Z/016		100	1800	9,50	M	
		Z/A16		100	1800	9,50	M	
OCTAVIA III estate (incl. RS, Scout)	02/13-12/19	Z/016		100	1800	9,50	M	
		Z/A16		100	1800	9,50	M	
OCTAVIA IV (NX3)	01/2020-	Z/035		100	2072	10,40	M	
		Z/A35		100	2072	10,40	M	
OCTAVIA IV estate (NX5)	11/2019-	Z/035		100	2072	10,40	M	
		Z/A35		100	2072	10,40	M	
RAPID liftback (excl. Scoutline)	07/12-	Z/017		75	1500	8,00	M	
RAPID SPACEBACK (incl. Scoutline)	10/13-	Z/018		75	1500	8,00	M	
RAPID saloon	10/12-	Z/018		75	1500	8,00	M	
ROOMSTER	09/06-05/15	Z/012		60	1200	6,73	M	
SCALA	18-	Z/031		100	1850	9,14	M	
		Z/A31		100	1850	9,14	M	
SUPERB I	03/02-08/08	W/012		85	2000	10,20		-
SUPERB II	09/08-05/15	Z/013		75	1800	9,58	M	
		Z/A13		75	1800	9,86	M	

























































 BRAND & MODEL	building year 	CAT NO.	 type of coupling	 vertical load	 max. towing weight	D-Value (kN)	electr. module	 bumper cut
SUPERB II estate	01/10-05/15	Z/013		75	1800	9,58	M	
		Z/A13		75	1800	9,86	M	
SUPERB III (excl. 4x4)	05/15-	W/041		100	2235	11,50	M	
SUPERB III estate (excl. 4x4)	05/15-	W/041		100	2235	11,50	M	
YETI	11/09-12/13	Z/015		80	2000	10,00	M	
YETI	04/14-	Z/020		80	2000	10,00	M	
SSANG YONG								
KORANDO (CW) (incl. AdBlue, 4WD)	17-	S/074		120	2100	11,6	M	-
		S/A74		120	2100	11,6	M	-
MUSSO GRAND	06/19-	S/075		215	3680	17,6	M	-
REXTON (excl. Parking sensors)	07/06-01/17	S/051		140	2300	15,14		-
REXTON	17-	S/073		140	3500	15,85	M	
SUBARU								
FORESTER (SF, SG)	09/97-03/08	U/001		75	2000	10,00		-
FORESTER (SH)	04/08-02/13	U/005		80	2000	10,00		
		U/A05		80	2000	10,00		
FORESTER (SJ)	03/13-03/18	U/007		80	2150	10,10	M	
FORESTER (SK)	04/18-	U/011		100	2100	10,50	M	
		U/A11		100	2100	10,50	M	
LEGACY OUTBACK	09/09-02/15	U/006		82	2000	10,05		
		U/A06		82	2000	10,05		
OUTBACK	03/15-08/20	U/009		90	2000	10,52	M	
		U/A09		90	2000	10,52	M	
OUTBACK	09/20-	U/012		125	2100	10,80	M	
		U/A12		125	2100	10,80	M	
SOLTERRA	12/21-	T/082		80	913	6,60	M	
		T/A82		80	913	6,60	M	
TRIBECA	09/06-01/14	U/003		80	2000	11,10	M	-
		U/A03		80	2000	11,10	M	-
XV II	04/17-	U/010		100	1940	9,82	M	-
		U/A10		100	1940	9,82	M	-
SUZUKI								
GRAND VITARA	03/98-09/05	V/027		75	1850	9,80		-
GRAND VITARA 5d	10/05-05/15	V/026		85	2000	10,50		
JIMNY IV	10/18-	V/053		90	1500	7,40	M	-
		V/A53		90	1500	7,40	M	-
KIZASHI 4D	10-14	V/052		75	1700	9,30		
SWIFT 3, 5 doors	89-98	V/029		50	1000	5,45		-
SX4 (APV) 2WD, 4WD (RW)	06/06-12/15	F/026		75	1250	7,30	M	-
		F/A26		75	1250	7,30	M	-
SX4 S-cross (AK)	13-	V/032		75	1500	8,30	M	
VITARA	15-	V/050		75	1500	8,44	M	



 BRAND & MODEL	building year 	CAT NO.	 type of coupling	 vertical load	 max. towing weight	D-Value (kN)	electr. module	 bumper cut
TOYOTA								
AURIS htb. (excl. 2.2 HDI)	10/06-09/12	T/035		60	1600	8,60		-
AURIS htb. (excl. Hybrid)	10/12-	T/069		75	1600	8,80	M	
AURIS estate (excl. Hybrid)	06/13-12/18	T/060		75	1300	8,60	M	-
		T/A60		75	1723	8,84	M	-
AVENSIS liftback (T22)	11/97-02/03	T/001		75	1550	8,17		
AVENSIS saloon (T22)	11/97-02/03	T/001		75	1550	8,17		
AVENSIS liftb. saloon	01/03-11/08	T/023		75	1400	8,61		-
AVENSIS saloon	01/03-11/08	T/023		75	1400	8,61		-
AVENSIS estate	04/03-11/08	T/024		75	1400	8,61		-
AVENSIS VERSO	04/02-03/09	T/025		75	1750	9,70		
AVENSIS saloon	01/09-	T/036		75	1800	10,70	M	-
		T/A36		75	1800	10,70	M	-
AVENSIS estate	01/09-	T/037		75	1800	10,70	M	-
		T/A37		75	1800	10,70	M	-
BZ4X	12/21-	T/082		80	913	6,60	M	
		T/A82		80	913	6,60	M	
C-HR (incl. Hybrid)	10/16-	T/070		80	1638	8,70	M	-
		T/A70		80	1638	8,70	M	-
COROLLA saloon (E10)	05/92-06/97	T/007		75	1400	7,32		-
COROLLA saloon (E11)	07/97-06/02	T/007		75	1400	7,32		-
COROLLA liftback (E11)	07/97-06/02	T/007		75	1400	7,32		-
COROLLA estate (E12)	01/02-12/07	T/019		55	1350	7,91		-
COROLLA htb. (E12)	01/02-02/07	T/021		50	1350	7,91		-
COROLLA Verso (E12)	12/01-05/04	T/031		55	1400	8,21		
COROLLA saloon (E15)	10/06-05/13	T/045		60	1800	8,60		
COROLLA Verso (R1)	04/04-03/09	T/032		60	1450	8,61		
COROLLA saloon (E18)	06/13-	T/061		60	1300	8,60	M	
COROLLA htb. (incl. Hybrid)	01/19-	T/070		80	1638	8,70	M	-
		T/A70		80	1638	8,70	M	-
COROLLA saloon (incl. Hybrid)	01/19-	T/071		80	1980	9,41	M	
		T/A71		80	1980	9,41	M	
COROLLA Touring Sports (incl. Hybrid)	01/19-	T/071		80	1980	9,41	M	
		T/A71		80	1980	9,41	M	
COROLLA Cross (G1)	03/21-	T/071		80	1980	9,41	M	
		T/A71		80	1980	9,41	M	
HIGHLANDER	11-	T/050		120	2200	12,25	M	-
HIGHLANDER	14-21	T/057		120	2200	12,25	M	-
HIGHLANDER	21-	T/078		80	2000	11,90	M	
		T/A78		80	2000	11,90	M	
HILUX 4x4, tyres R15	10/05-07/10	T/030		120	2800	13,80		-
HILUX	08/10-	T/046		120	2800	13,80		-

 BRAND & MODEL	building year 	CAT NO.	 type of coupling	 vertical load	 max. towing weight	D-Value (kN)	electr. module	 bumper cut
HILUX REVO	01/15-	T/103		140	3535	16,50	M	
LANDCRUISER J90	04/96-12/02	T/016		130	2800	13,73		-
LANDCRUISER 5d J12	01/03-10/09	T/028		130	2800	16,30		
LANDCRUISER 5d J12	01/03-10/09	T/104		130	3500	16,50		
LANDCRUISER 3d/5d J15	11/09-	T/028		130	2800	16,30	M	
LANDCRUISER J200	03/08-	T/039		140	3500	17,40	M	
		T/A39		140	3500	17,40	M	
PROACE	03/16-	C/042		100	2500	13,60	M	-
		C/A42		100	2500	13,60	M	-
PROACE Verso	03/16-	C/042		100	2500	13,60	M	-
		C/A42		100	2500	13,60	M	-
PROACE CITY (L1)	05/19-	C/029		80	1600	8,69	M	-
		C/A29		80	1600	8,69	M	-
PROACE CITY (L2)	05/19-	C/045		75	1600	9,43	M	-
		C/A45		75	1600	9,43	M	-
RAV-4 (excl. USA version)	01/05-04/10	T/027		90	2050	10,41		-
RAV-4 5 doors, 4x4, tyres 15/70, R16	00-05	T/026		75	1745	8,80		-
RAV-4 (incl. Hybrid)	02/13-10/18	T/041		80	2000	10,90	M	
RAV-4	11/18-	T/072		80	2000	10,90	M	
		T/A72		80	2000	10,90	M	
SIENNA	12/09-	T/040		75	1800	11,00	M	
TUNDRA	08-	T/076		150	3500	17,17		-
VERSO	04/09-	T/042		55	1300	8,10	M	
VERSO S	03/11-	T/043		50	900	5,84	M	
YARIS htb. (C,E) 3/5 doors	04/99-12/05	T/022		50	900	5,37		-
YARIS	05-	T/038		50	1000	6,30	M	
YARIS	06/20-	T/A81		60	1000	6,10	M	
YARIS Verso	01/00-09/05	T/034		50	900	5,37		-
YARIS CROSS	07/21-	T/079		95	1500	8,00	M	
		T/A79		95	1500	8,00	M	
VOLKSWAGEN								
AMAROK	08/10-	W/035		120	2800	14,30	M	
BORA estate (excl. 4motion)	05/99-05/05	W/009		75	1600	8,91		
BORA saloon	10/98-05/05	W/018		75	1650	9,06		
GOLF IV	08/97-10/03	W/018		75	1650	9,06		
GOLF IV estate	12/98-12/06	W/009		75	1600	8,91		
GOLF V (excl. Cross)	12/03-02/08	W/028		75	1850	9,20	M	
GOLF V PLUS (excl. Cross)	02/05-05/14	W/028		75	1850	9,20	M	
GOLF V estate	05/07-06/09	W/030		75	1742	9,20	M	
GOLF VI estate	07/09-13	W/030		75	1742	9,20	M	
GOLF VI	09/08-08/12	W/028		75	1850	9,20	M	

 BRAND & MODEL	building year 	CAT NO.	 type of coupling	 vertical load	 max. towing weight	D-Value (kN)	electr. module	 bumper cut
GOLF VII (incl. GTI) (excl. R-line, E-Golf, GTE Hybrid)	09/12-06/19	Z/016		100	1800	9,50	M	
		Z/A16		100	1800	9,50	M	
GOLF VII Sportsvan (incl. GTI)	06/14-	Z/016		100	1800	9,50	M	
		Z/A16		100	1800	9,50	M	
GOLF VIII (CD1)	07/2019 -	Z/035		100	2072	10,40	M	
		Z/A35		100	2072	10,40	M	
GOLF VIII estate (CG5)	08/2020-	Z/035		100	2072	10,40	M	
		Z/A35		100	2072	10,40	M	
JETTA	06/05-01/11	W/030		75	1742	9,20	M	
JETTA (excl. Hybrid)	01/11-	W/037		75	1800	9,30	M	-
CADDY (incl. Maxi) (excl. CNG, 4WD)	02/04-08/20	W/027		80	1650	9,40	M	-
		W/A27		80	1650	9,40	M	-
CADDY	09/20-	W/056		119	1620	9,80	M	-
		W/A56		119	1620	9,80	M	-
CRAFTER 3665/4325 VAN (single/double tyres)	04/06-12/16	M/021		140	3500	20,20	M	-
CRAFTER 5T, 3665/4350 pick-up (double tyres)	04/06-	M/024		140	3500	20,20	M	-
CRAFTER 3,25/3,65/4,32 VAN with footboard (single tyres)	04/06-12/16	M/031		100	2800	15,24	M	-
CRAFTER 3T; 3,5T;4,6T pick-up (single tyres)	04/06-	M/021		140	3500	20,20	M	-
CRAFTER II VAN (excl. integrated step in the bumper) (single tyres)	11/16-	W/049		150	3500	17,17	M	-
CRAFTER II VAN (incl. integrated step in the bumper) (single tyres)	09/16-	W/055		150	3500	20,55	M	-
CRAFTER II 3640/4490 pick-up, (single tyres)	11/16-	W050		140	3500	17,17	M	-
CRAFTER II (single/double tyres)	02/17-	W/052		150	3500	17,50	M	-
LT 28-35 3,55 m, 4,025 m	12/95-05/06	M/007		120	2800	15,85		-
LT 28-35 3,55m/4,025m with footboard	12/95-05/06	M/012		120	2800	16,05		-
LT 28-35 pick-up, (single tyres)	12/95-05/06	M/015		100	2800	15,26		-
PASSAT B-5 saloon (excl.4Motion)	10/96-02/05	W/012		85	2000	10,20		-
PASSAT B-5 estate	05/97-08/05	W/012		85	2000	10,20		-
PASSAT B-6 saloon	03/05-09/10	W/026		85	2000	10,20	M	
		W/A26		85	2000	10,20	M	
PASSAT B-6 estate	03/05-10/10	W/026		85	2000	10,20	M	
		W/A26		85	2000	10,20	M	
PASSAT B-7 saloon	10/10-12/14	W/036		90	2200	11,30	M	
PASSAT B-7 estate	10/10-12/14	W/036		90	2200	11,30	M	
PASSAT B-8 saloon	08/14-	W/041		100	2235	11,50	M	
		W/A41		100	2235	11,50	M	
PASSAT B-8 estate (incl. Alltrack)	11/14-	W/041		100	2235	11,50	M	
		W/A41		100	2235	11,50	M	
POLO CLASSIC saloon	10/95-09/03	S/002		50	1200	6,70		

 BRAND & MODEL	building year 	CAT NO.	 type of coupling	 vertical load	 max. towing weight	D-Value (kN)	electr. module	 bumper cut
POLO estate	04/97-09/01	S/002		50	1200	6,70		
POLO htb. (6N)	10/94-01/02	W/021		50	1200	6,73		
POLO htb. (9N) (excl. FUN)	11/01-11/09	W/022		50	1200	6,90		
POLO htb. (6R) (excl. BlueMotion, GT, GTI, WCR)	04/09-10/17	W/034		85	1350	7,50	M	
POLO VI htb. (excl. GTI, CNG)	06/17-	S/017		75	1200	6,92	M	-
		S/A17		75	1200	6,92	M	-
SHARAN (excl. Parktronic)	06/95-04/00	E/010		85	2100	11,20		-
SHARAN	05/00-09/10	E/030		100	2100	12,50		-
SHARAN	07/10-06/12	W/038		100	2500	12,50	M	
SHARAN 5D VAN	06/12-	W/046		100	2500	12,50	M	-
		W/A46		100	2500	12,50	M	-
T-4 Furgon	09/90-01/96	W/016		100	2600	13,40		-
T-5 Pick-up	04/03-06/15	W/029		100	2500	14,40	09>	-
T-5	01/03-06/15	W/023		120	2800	14,18	09>	-
T-6 Pick-up	07/15-	W/029		100	2500	14,40	M	-
T-6	07/15-	W/023		120	2800	14,18	M	-
T-7 Multivan	06/21-	W/057		140	2000	12,00	M	-
		W/A57		140	2000	12,00	M	-
T-CROSS	04/19-	S/017		75	1200	6,92	M	-
		S/A17		75	1200	6,92	M	-
T-ROC	18-	W/047		100	2000	10,30	M	
		W/A47		100	2000	10,30	M	
TOURAN	03/03-08/15	W/025		75	1825	9,90	M	
		W/A25		75	1825	9,90	M	
TOURAN (excl. R-line)	05/15-	W/043		80	1800	9,92	M	
		W/A43		80	1800	9,92	M	
TOUAREG I	10/02-03/10	W/031		140	3500	16,40	M	
		W/A31		140	3500	16,40	M	
TOUAREG II (excl. R-Line)	04/10-09/14	W/031		140	3500	16,40	M	
		W/A31		140	3500	16,40	M	
TOUAREG III	11/17-	W/051		140	3500	16,40	M	
		W/A51		140	3500	16,40	M	
TIGUAN (excl. R-Line)	09/07-01/16	W/033		100	2500	12,00	M	
		W/A33		100	2500	12,00	M	
TIGUAN	01/16-	Z/023		140	2500	12,62	M	
		Z/A23		140	2500	12,62	M	
UP!	12/11-	Z/019		50	850	5,15	M	
		Z/A19		50	850	5,15	M	
VOLVO								
S 40	07/95-08/03	V/004		75	1500	8,50		-
V 40	07/95-02/04	V/004		75	1500	8,50		-

 BRAND & MODEL	building year 	CAT NO.	 type of coupling	 vertical load	 max. towing weight	D-Value (kN)	electr. module	 bumper cut
S40	01/04-	V/014		75	1600	8,91	M	
		V/A14		75	1600	8,91	M	
V 40 htb. Cross country	10/12-	V/038		75	1500	8,67	M	-
		V/A38		75	1500	8,67	M	-
V50	04/04-02/12	V/016		75	1600	8,91	M	
		V/A16		75	1600	8,91	M	
S60	11/00-05/10	V/036		85	1600	9,10	M	
S 60 (excl. T6, Polestar, R-Design, Crosscountry)	06/10-01/18	V/033		90	1950	10,80	M	
V 60 (excl. T6, Polestar, R-Design, Cross country)	11/10-01/18	V/033		90	1950	10,80	M	
S70	97-02/00	V/007		75	1800	10,00	M	-
V 70	97-02/00	V/007		75	1800	10,00	M	-
V70	03/00-08/07	V/009		75	2000	10,30	M	-
V70	09/07-04/16	V/015		90	2100	11,00	M	
		V/A15		90	2100	11,00	M	
S80	05/98-12/05	V/011		90	2000	12,20	M	
S80	01/06-	V/018		90	2100	11,00	M	
		V/A18		90	2100	11,00	M	
S90 (excl. Cross Country, R-Design)	03/16-	V/041		140	2500	12,55	M	
		V/A41		110	2055	11,30	M	
V90 (incl. 4WD) (excl. Cross Country, R-Design)	03/16-	V/041		140	2500	12,55	M	
		V/A41		110	2055	11,30	M	
XC 40	10/17-	V/037		110	2157	10,80	M	
		V/A37		110	2157	10,80	M	
XC 60	11/08-12/16	V/017		90	2100	10,99	M	
		V/A17		90	2100	10,99	M	
XC 60	17-	V/035		140	2400	12,40	M	
		V/A35		140	2400	12,40	M	
XC 70	10/07-	V/020		90	2100	10,99	M	
		V/A20		90	2100	10,99	M	
XC90	01/03-12/14	V/012		75	2250	10,30	M	
		V/A12		75	2200	10,30	M	
XC90	05/15-	V/034		140	2700	13,40	M	
		V/A34		140	2700	13,40	M	
USA TOWBALL								
USA TOWBALL		AM/101		150	3500	18,50		
USA TOWBALL		AM/102		200	3500	22,50		
USA TOWBALL		AM/103		100	2000	12,49		
TOWBALL		SM/200		112	3500	19,80		
USA TOWBALL		SM/203		200	3500	17,17		

ACCESSORIES	TYPE	BRUTTO PRICES PLN
Ball		65,00
Ball		80,00
Standard wiring kits 1,75 m	W175	15,00
Standard wiring kits 2,20 m	W220	16,00
Module UniKIT - 1L	UniKit - 1L	220,00
Module UniKIT - 2G	UniKIT - 2G	240,00
Module UniKIT - 3G	UniKIT - 3G	280,00

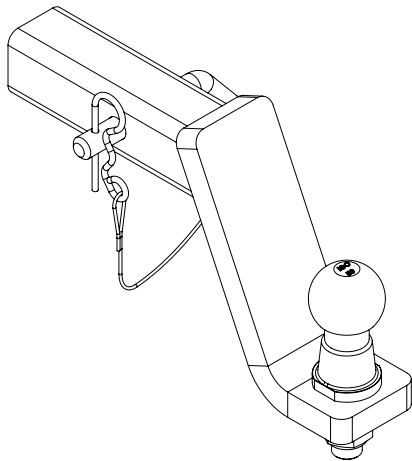

Type AM-101

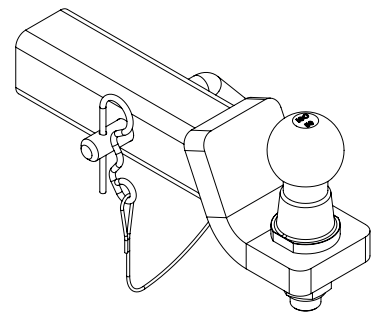

Type AM-103

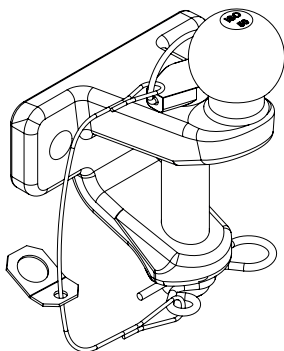

Type SM-200

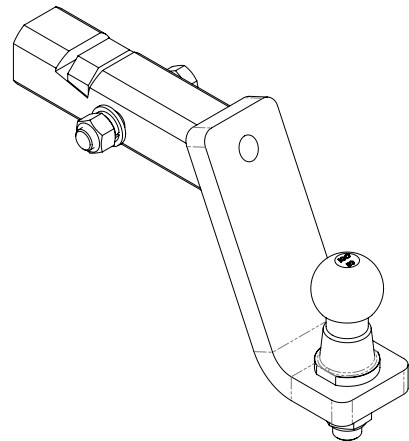

Type SM-203

NOTES

A series of horizontal dotted lines spanning the width of the page, intended for writing notes.

NOTES

A series of horizontal dotted lines spanning the width of the page, intended for writing notes.

NOTES

A series of horizontal dotted lines spanning the width of the page, intended for writing notes.