

Ball type A

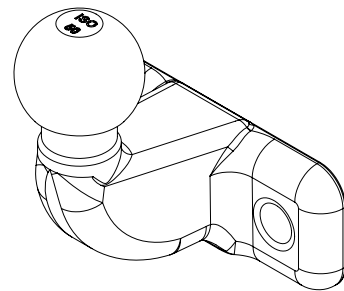

Ball type B

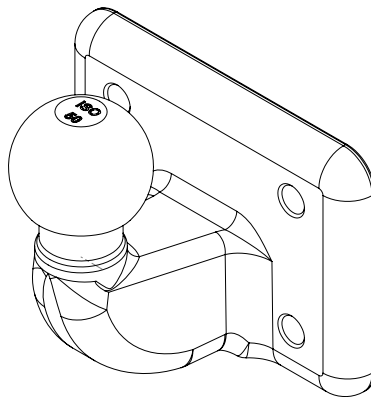

Ball type C

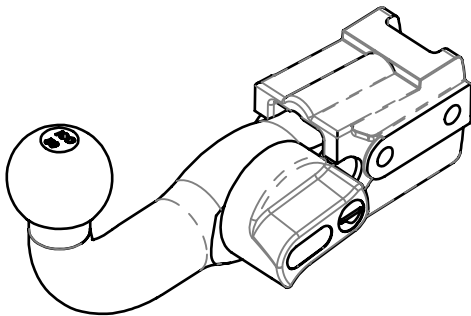

Ball type H

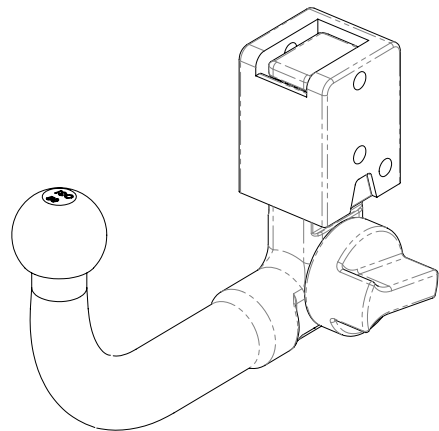

Ball type V





Imiola HAK-POL a été créée en 1991. Nous sommes spécialisés dans la fabrication d'attache-remorques et proposons plus de cinq cents modèles pour voitures de tourisme et véhicules utilitaires. Pour assurer à la fois la qualité et la précision de nos produits, les éléments nécessaires à la production d'attache-remorques sont fabriqués à l'aide de machines modernes à commande numérique (CNC) telles que des découpeuses au laser, des postes de soudage robotisés et des presses plieuses. Pour assurer la meilleure tenue dans le temps, nos attelages, après grenailage et phosphatation reçoivent une couche de peinture en poudre polyester.

La société HAK-POL a mis en place et utilise un système de gestion de la qualité répondant aux exigences de: PN- EN ISO 9001: 2015-10 dans le domaine de la conception, fabrication, vente de barres de remorquage et service de coupe au laser.

Tous nos produits disposent de l'homologation européenne e20 et E20. De plus, nous possédons un certificat EAC attestant que le produit est conforme aux normes de qualité et de sécurité des marchés des États membres de l'Union Douanière Eurasiatique.

Afin d'obtenir les homologations, nos attelages sont testés par le laboratoire PIMOT: institution habilitée par le ministère de l'Infrastructure à fournir et à délivrer de telles certifications.

En vertu de notre accord, PIMOT Varsovie assure le suivi de la qualité de nos produits.

Nous commercialisons actuellement nos attache-remorques dans 12 pays européens avec un succès toujours croissant.



Imiola HAK-POL werd in 1991 opgericht. We zijn gespecialiseerd in het produceren van trekhaken en bieden meer dan vijfhonderd modellen aan voor bedrijfswagen en toerisme wagens. Om zowel de kwaliteit als de precisie van onze producten te garanderen, worden de nodige elementen voor het produceren van trekhaken, aan de hand van moderne machines (CNC) gemaakt zoals lasersnijders, robot lasmachines en afkantpersen. De beste duurzaamheid garanderen we met een laag polyesterpoederverf na het gritstralen en een fosfaatbehandeling van onze koppelingen.

HAK-POL heeft een kwaliteitsmanagementsysteem geïmplementeerd dat voldoet aan de vereisten van: PN- EN ISO 9001: 2015-10 op het gebied van ontwerpen, produceren en verkopen van trekhaken en lasersnijservice.

Al onze producten hebben de Europese goedkeuring e20 en E20. Daarnaast hebben we een EAC-certificaat waaruit blijkt dat het product voldoet aan de kwaliteits- en veiligheidsnormen van de markten van de lidstaten van de Euraziatische douane-unie.

Om goedkeuringen te verkrijgen worden onze koppelingen getest door het PIMOT-laboratorium, instelling die door het ministerie van Infrastructuur gemachtigd is om dergelijke goedkeuringen en certificaten te verstrekken.

Krachtens de overeenkomst, PIMOT Warschau verzekert de kwaliteitscontrole van onze producten.

Momenteel verkopen we onze trekhaken in 12 Europese landen met toenemend succes.



Imiola HAK-POL was established in 1991. We specialize in manufacturing tow bars for over five hundred models of passenger cars and delivery vans. To ensure both high quality and precision of our products the elements needed for tow bars production are made with the use of modern CNC (Computer Numerically Controlled) machines such as laser cutting machines, robotic welding stand and punching press. To ensure the best possible protection for our tow bars they are cleaned in the blast cleaning chamber and phosphor coated before receiving their final coat of polymer powder paint.

HAK-POL company has implemented and uses a management system satisfying the requirements of: PN- EN ISO 9001:2015-10 – the scope of certification: DESIGN, MANUFACTURE AND SALE OF TOW BARS AND LASER CUTTING SERVICES.

The quality of our products is confirmed by the e20 and E20 EU approvals. Additionally, we possess an EAC certificate that confirms that the product is compliant with quality and safety standards that are binding on the markets of the Customs Union Member States, i.e. Russia, Kazakhstan and Belarus.

In order to obtain homologations our tow bars are tested by the Automotive Industry Institute (PIMOT) laboratory. The PIMOT laboratory is the institution authorized by the Ministry of Infrastructure to provide and grant such certifications.

Under the agreement, the Automotive Industry Institute (PIMOT) in Warsaw keeps control over our production.

We currently sell our products in 12 European countries from which we receive an ever increasing amount of interest.







 BRAND & MODEL	building year 	CAT NO.	 type of coupling	 vertical load	 max. towing weight	D-Value (kN)	 bumper cut
AUDI							
80 excl. QUATRO	08/86-10/91	A/003		50	1500	8,23	
80 (B-4) excl. CABRIO	11/91-95	A/004		75	1865	9,90	
A1 3,5D	07.10-02.15	W/034		85	1350	7,50	
A-1	05/10-	Z/025		85	1415	7,50	
		Z/A25		85	1415	7,50	
A3	96-06/03	W/018		75	1600	8,91	
A3 (EXL. SPORTBACK)	06/03-07/12	W/028		75	1850	9,20	
A3 Sportback, Cabrio S-line, Limusine	13-	Z/016		100	1800	9,50	
		Z/A16		100	1800	9,50	
A-4 berline, incl. QUATRO	94-10/00	A/010		75	1800	9,47	
A-4 Avant, incl. QUATRO	12/95-05/01	A/010		75	1800	9,47	
A-4 berline, incl. QUATRO	11/00-07	A/011		80	2000	10,71	
		A/A11		75	1800	9,47	
A-4 saloon (B9), QUATRO excl. RS	01/16-	A/023		95	2100	11,00	
		A/A23		95	2100	11,00	
A-4 saloon (B9), QUATRO excl. Sensor	01/16-	A/023		95	2100	11,00	
		A/A23		95	2100	11,00	
A-4 Avant, incl. QUATRO	06/01-07	A/011		80	2000	10,71	
		A/A11		80	2000	10,71	
A-4 berline, break (excl. S-LINE; S4)	08-12/15	A/014		90	2100	10,90	
		A/A14		90	2100	10,90	
A-5 COUPE; HTB; SPORTBACK (excl S-line; S4)	08-01/17	A/014		90	2100	10,90	
		A/A14		90	2100	10,90	
A-5(F5) excl. RS	01/16-	A/023		95	2100	11,00	
		A/A23		95	2100	11,00	
A-6 berline; AVANT, QUATTRO	04/97-03/05	A/008		85	2055	10,90	
A-6 4 doors, incl. QUATTRO	04-02/12	A/012		85	2100	10,90	
		A/A12		85	2100	10,90	
A-6 break	05-09/11	A/012		85	2100	10,90	
		A/A12		85	2100	10,90	
A-6, AVANT, incl. QUATRO	03/11-	A/019		100	2500	12,60	
		A/A19		100	2500	12,60	
A-7, AVANT, incl. QUATRO	03/11-	A/019		100	2500	12,60	
		A/A19		100	2500	12,60	
A-8 (4D) QUATRO, long	11/09-01/18	A/022		100	2300	12,60	
		A/A22		100	2300	12,60	
Q 2	11/16-	Z/016		100	1800	9,50	
Q 3 + S LINE	2012-	W/033		100	2500	12,00	
		W/A33		100	2500	12,00	

 BRAND & MODEL	building year 	CAT NO.	 type of coupling	 vertical load	 max. towing weight	D-Value (kN)	 bumper cut
Q 5	08-12/16	A/016		100	2400	11,88	
		A/A16		100	2400	11,88	
Q 5	17-	A/021		100	2400	11,90	
		A/A21		100	2400	11,90	
Q 7 T (4LB)	03/06-08/15	A/015		140	3500	16,40	
		A/A15		140	3500	16,40	
Q 7 T (4MB)	09/15-	A/017		140	3500	16,40	
		A/A17		140	3500	16,40	
BMW							
1 -SERIES E81/E87/E88	10/04-07/11	B/010		75	1900	10,00	
		B/A10		75	1900	10,00	
1 - SERIES (F20/201) (HB)	06/11-	B/021		100	1944	10,00	
		B/A21		100	1944	10,00	
2 -SERIES (F22), (F46)	08/13-	B/021		100	1944	10,00	
		B/A21		100	1944	10,00	-
3 - SERIES E 36 break	95-08/99	B/001		80	1800	9,30	
3 - SERIES E 36 berline	01/91-03/98	B/001		80	1800	9,30	
3-SERIES E 36 4 doors; coupe; berline	01/91-03/98	B/001		80	1800	9,30	
3 - SERIES E 36 compact (excl. M3)	94-01	B/012		75	1600	8,20	
3 - SERIES E 46 4 doors; coupe	04/98-05	B/007		75	1800	9,51	
3 - SERIES E 46 COMPACT	06/01-05	B/007		75	1800	9,51	
3 - SERIES E 46 break	98-02/05	B/011		75	1865	9,69	
3 - SERIES E 90 sedan (excl. 335i/335d)	03/05-11	B/010		75	1900	10,00	
		B/A10		75	1900	10,00	
3 - SERIES E 91 break (excl. 335i/335d)	10/05-11	B/010		75	1900	10,00	
		B/A10		75	1900	10,00	
3 - SERIES (F30, F31)	02/12-	B/021		100	1944	10,00	
		B/A21		100	1944	10,00	
4 - SERIES (F32, F33, F36)	13-	B/021		100	1944	10,00	
		B/A21		100	1944	10,00	
5 - SERIES E 39 berline	12/95-10/03	B/004		90	2100	10,30	
5 - SERIES E 39 break	02/97-04	B/005		90	1800	10,65	
5 - SERIES E 61 (excl. M-5)	04-04/10	B/008		90	2000	11,40	
		B/A08		90	2000	11,40	
5 - SERIES E 60 (excl. M-5)	03-02/10	B/008		90	2000	11,40	
		B/A08		90	2000	11,40	
5 - SERIES F10 sedan excl M5, M550	10-	B/020		100	2200	11,80	-
		B/A20		100	2200	11,80	-

































































 BRAND & MODEL	building year 	CAT NO.	 type of coupling	 vertical load	 max. towing weight	D-Value (kN)	 bumper cut
5 - SERIES F11 break	10-	B/020		100	2200	11,80	-
		B/A20		100	2200	11,80	-
X1 /E84/	09-6/15	B/016		85	2000	10,85	-
X3 /E83/	04-12/11	B/009		80	2000	10,85	-
		B/A09		80	2000	10,85	
X3 /F25/ (excl X3M)	09/10-	B/017		100	2400	12,00	
X4 /F26/	07/14-	B/017		100	2400	12,00	
		B/A17		100	2400	12,00	
X5 /E53/	00-07	B/A13		120	3500	13,50	-
X5 /E70/	07-13	B/014		150	3500	16,53	
		B/A14		150	3500	16,53	
X5 /F15, F85/	08/13-07/18	B/014		150	3500	16,53	
		B/A14		150	3500	16,53	
X6 /E71/	08-7/14	B/018		140	3500	16,00	
		B/A18		140	3500	16,00	
X6 /F16, F86/	08/14-	B/014		150	3500	16,53	
		B/A14		150	3500	16,53	
CHEVROLET							
AVEO berline	06-11	CH/007		75	1400	6,70	-
AVEO hatchback 3,5 doors	08-11	CH/010		50	1200	6,60	
AVEO HTB	03/11-	CH/014		44	1100	6,62	-
CAPTIVA (C 100) (C 140)	06-10 11-	CH/009		80	2000	11,00	
		CH/A09		80	2000	11,00	
CRUZE sedan HTB	10-	CH/012		75	1800	9,60	-
LACETTI break	04-10	CH/005		75	1240	7,20	-
LACETTI 5 doors	03-10	CH/004		75	1200	7,00	-
LACETTI berline	05-10	CH/008		75	1300	7,00	-
ORLANDO	11-	CH/011		75	1600	9,90	-
TRAX	13-	O/044		75	1500	8,75	-
CHRYSLER							
VOYAGER COUNTRY	03/96-04/01	CH/002		80	1600	9,80	-
VOYAGER	05/01-01/08	CH/003		80	1600	9,90	
GRAND VOYAGER	03/96-04/01	CH/002		80	1600	9,80	-
GRAND VOYAGER	05/01-01/08	CH/003		80	1600	9,90	
GRAND VOYAGER	02/08-	CH/025		140	2025	11,53	-
		CH/A25		140	2025	11,53	-
GRAND VOYAGER LWB STOW'n GO	05-08	CH/022		80	1800	10,70	
PACIFICA	03-08	CH/024		80	1800	11,00	-

 BRAND & MODEL	building year 	CAT NO.	 type of coupling	 vertical load	 max. towing weight	D-Value (kN)	 bumper cut
CITROEN							
BERLINGO	11/96-08	C/012		70	1100	7,00	-
BERLINGO SWB vehicle lenght 4380	05/08-	C/029		80	1600	8,69	-
		C/A29		80	1600	8,69	-
BERLINGO LWD 4680	05/08-	C/036		65	1600	8,69	-
		C/A36		65	1600	8,69	-
BERLINGO III XL (L2)	08/16-	C/045		75	1600	9,43	-
		C/A45		75	1600	9,43	-
BERLINGO III (chassis model L1)	18-	C/029		80	1600	8,69	-
		C/A29		80	1600	8,69	-
C-ELYSSE	13-	C/040		55	1010	6,41	
C-Crosser	07-08/12	Y/024		100	2000	11,00	
		Y/A24		100	2000	11,00	
C-3 I htb.	02-09	C/016		50	1100	6,10	-
C-3 II htb.	10-09/16	C/031		54	1250	7,01	-
C-3 II PICASSO	09-	C/032		61	1200	7,20	-
C-3 III htb.	16-	P/040		55	1300	7,20	-
		P/A40		55	1300	7,20	-
C-3 Aircross	06/17-	C/044		75	1625	7,70	
		C/A44		75	1625	7,70	
C-4 Aircross	03/12-	Y/028		70	1500	8,96	
		y/A28		70	1500	8,17	
C-4 5 doors, htb.	04-09/10	C/020		66	1500	8,05	-
C-4 htb.	10-	C/033		66	1500	8,05	-
C4 CACTUS	09/14-	C/043		55	825	5,35	-
		C/A43		55	825	5,35	-
C-4 PICASSO	03/07-04/11	C/035		75	1800	9,71	-
		C/A35		75	1800	9,71	-
C-4 II PICASSO	13-	C/039		70	1750	9,56	
		C/A39		70	1750	9,56	
C-4 GRAND PICASSO	06-12/13	C/035		75	1800	9,71	-
		C/A35		75	1800	9,71	-
C-4 GRAND PICASSO	06/13-	C/039		70	1750	9,56	-
C-4 GRAND PICASSO	13-	C/A39		70	1750	9,56	
C-4 SPACETOURIER	03/18-	C/039		70	1750	9,56	-
		C/A39		70	1750	9,56	-
C-4 GRAND SPACETOURER	03/18-	C/039		70	1750	9,56	-
		C/A39		70	1750	9,56	-
C-5 hatchback	00-04	C/017		75	1700	9,32	-
C-5 break	00-12/04	C/021		85	1600	10,20	-
C-5 5 doors	10/04-08	C/022		75	1600	9,17	-

 BRAND & MODEL	building year 	CAT NO.	 type of coupling	 vertical load	 max. towing weight	D-Value (kN)	 bumper cut
C-5 berline	08-	C/037		80	1900	10,40	-
		C/A37		80	1900	10,40	-
C-5 break (excl. 2.2 HDI/3.0 HDI)	05/08-	C/038		80	1900	10,40	-
		C/A38		80	1900	10,40	-
C-5 Aircross	11/18-	P/044		100	2000	10,00	
		P/A44		100	2000	10,00	
C8	05-13	F/020		80	1900	10,20	
EVASION	94-01	P/016		80	1800	9,70	
JUMPER	05/94-12/02	C/005		110	2200	12,49	-
JUMPER	03-06/06	C/005		110	2200	12,49	-
JUMPER VAN, III L1, L2, L3	07/06-	C/018		100	3000	15,09	
JUMPER III pick-up, L1, L2, L3	06-	C/025		120	3100	15,09	-
JUMPER III L4 VAN	08-	C/030		120	3100	16,13	
JUMPY I	94-12/06	P/016		80	1800	9,70	
JUMPY II T(VF)	07-09/16	F/023		80	2000	11,93	
		F/A23		80	2000	11,93	
JUMPY III	01/16-	C/042		100	2500	13,60	-
		C/A42		100	2500	13,60	-
NEMO	08-	F/027		60	1100	6,83	-
XSARA hatchback	97-04	C/013		70	1300	7,21	
XSARA break	98-05	C/015		70	1300	7,30	-
XSARA PICASSO	99-06	C/014		80	1300	7,56	-
DAEWOO							
NEXIA berline	95-97	D/003		50	1200	6,80	-
LANOS hatchback	97-	D/004		50	1100	6,40	-
LANOS berline	97-	D/005		50	1100	6,40	-
NUBIRA berline I i II	97-	D/007		75	1200	7,00	-
NUBIRA break I i II	97-	D/008		75	1200	7,20	-
MUSSO	10/98-	D/011		140	3500	11,00	-
KORANDO	98-	D/013		140	3500	11,00	-
DACIA							
DOKKER INCL STEPWAY	13-	G/006		75	1400	7,50	-
DUSTER (2/4 WD)	04/10-	G/005		75	1500	9,00	-
LOGAN berline	04-01/13	G/002		75	1100	6,40	-
LOGAN berline	13-	G/008		75	1100	6,47	-
LODGY	12-	G/007		75	1400	8,08	-
LOGAN break, van, express	07-13	G/003		75	1300	7,80	-
LOGAN (MCV) break	07/13-	G/010		75	1596	8,00	
SANDERO HTB	08-12/12	G/004		75	1355	7,30	-
SANDERO HTB, break	13-	G/009		75	1100	6,47	-



 BRAND & MODEL	building year 	CAT NO.	 type of coupling	 vertical load	 max. towing weight	D-Value (kN)	 bumper cut
DODGE							
Ram 1500	15-	AM/110		100	3500	22,00	-
Ram 1500 DT	15-	AM/107		350	3500	22,50	-
Ram 1500 DS	19-	AM/108		350	3500	22,50	-
FIAT							
ALBEA	02-	F/021		70	1300	6,90	
BRAVA htb. 5D	09/95-01	F/001		75	1400	7,90	-
BRAVO htb.	07-12/14	F/024		75	1400	7,90	-
		F/A24		75	1400	7,90	
CINQUECENTO	92-98	F/002		30	400	3,00	-
DOBLO T (223)	01-11/09	F/003		90	1300	7,58	
DOBLO T (263)	12/09-	F/031		65	1620	9,79	
		F/A31		65	1620	9,79	
DUCATO	04/94-02	C/005		110	2200	12,49	-
DUCATO	03-06/06	C/005		110	2200	12,49	-
DUCATO III VAN, L1 L2 L3	07/06-	C/018		100	3000	15,09	
DUCATO VAN, L4	06-	C/030		120	3100	16,13	
DUCATO III pick-up, L1 L2 L3	06-	C/025		120	3100	15,09	-
FIORINO	08-	F/027		60	1100	6,83	
LINEA	07-	F/025		75	1200	7,30	
MULTIPLA	11/98-04	F/015		70	1300	8,33	-
PANDA 2WD htb, VAN	03-11	F/022		60	900	6,33	-
PANDA III	02/12-	F/032		70	1000	6,10	-
PUNTO I	11/93-08/99	F/006		70	1300	6,80	-
PUNTO II	09/99-05	F/013		60	1200	6,73	-
PUNTO III (GRANDE)	09/05-06/13	F/029		60	1300	7,03	
SCUDO I	94-06	P/016		80	1800	9,70	
SCUDO II	07-	F/023		80	2000	11,93	
		F/A23		80	2000	11,93	
SCUDO III	16-	C/042		100	2500	13,60	-
		C/A42		100	2500	13,60	-
SEICENTO	98-03	F/012		28	400	3,46	-
SEIDICI	06-	F/026		75	1250	7,30	
		F/A26		75	1250	7,30	
SIENA	96-02	F/011		50	1300	6,97	
STILO hatchback 3/5 doors	01-07	F/018		60	1400	7,83	
TALENTO (L1, L2)	09/16-	R/066		100	2100	12,21	-
TIPO 5D	06/16-	F/035		100	1500	8,17	
		F/A35		100	1500	8,17	
ULYSSE I	94-01	P/016		80	1800	9,70	
ULYSSE II	02-06/11	F/020		80	1900	10,20	

 BRAND & MODEL	building year 	CAT NO.	 type of coupling	 vertical load	 max. towing weight	D-Value (kN)	 bumper cut
QUBO	08-	F/027		60	1100	6,83	
FORD							
B-MAX (MPU)	12-	E/052		65	900	6,00	-
		E/A52		65	900	6,00	-
C-MAX	02/07-09/10	E/037		75	1500	8,50	
		E/A37		75	1500	8,50	
EDGE	08/15-	E/058		120	2350	12,00	-
		E/A58		120	2350	12,00	-
ESCAPE (USA)	01/13-	E/051		105	2100	10,55	-
		E/A51		105	2100	10,55	-
ESCORT break/ORION	08/90-00	E/005		50	1200	7,00	-
FIESTA hatchback	02/96-02	E/009		50	950	5,70	-
FIESTA hatchback	01/02-07	E/032		50	900	5,61	
FIESTA hatchback	08-01/17	E/046		50	900	5,70	
FOCUS hatchback I	98-04	E/023		70	1400	7,80	-
FOCUS berline I	98-04	E/024		75	1600	8,03	-
FOCUS break I	98-04	E/025		75	1400	7,40	-
FOCUS II 3,5 doors	09/04-04/11	E/037		75	1500	8,50	-
		E/A37		75	1500	8,50	-
FOCUS berline II	05-03/11	E/044		75	1500	8,50	-
FOCUS II break	05-04/11	E/036		75	1500	8,50	
FOCUS III HTB	06/11-	E/048		75	1500	10,00	-
FOCUS 5D HB (Mk4)	04/18-	E/063		100	2100	10,00	
		E/A63		100	2100	10,00	
FOCUS III break	04/11-	E/047		75	1500	10,00	-
FOCUS C-MAX	04-	E/037		75	1500	8,50	
		E/A37		75	1500	8,50	
FUSION	02-13	E/034		50	1050	6,50	
GALAXY	06/95-05/00	E/010		85	2100	11,20	-
GALAXY	05/00-06	E/030		100	2100	12,50	-
GALAXY	06-06/15	E/038		100	2640	12,50	-
		E/A38		100	2640	12,50	
GALAXY	05/15-	E/056		90	2000	12,10	
KUGA	08-12	E/042		100	2100	10,50	-
		E/A42		100	2100	10,50	
KUGA	11/12-	E/051		105	2100	10,55	-
		E/A51		105	2100	10,55	-
MONDEO hatchback, berline	09/96-09/00	E/012		75	1800	8,90	
MONDEO break	05/93-09/00	E/028		75	2000	11,00	-
MONDEO break	10/00-12/06	E/028		75	2000	11,00	-

 BRAND & MODEL	building year 	CAT NO.	 type of coupling	 vertical load	 max. towing weight	D-Value (kN)	 bumper cut
MONDEO hatchback, berline	10/00-12/06	E/033		80	1800	11,00	-
MONDEO 4 doors, break, 5 doors	03/07-09/14	E/041		80	2120	11,60	break
		E/A41		80	2120	11,60	-
MONDEO HTB, SEDAN	09/14-	E/057		100	2532	11,90	-
MONDEO break	09/14-	E/057		100	2532	11,90	-
MAVERICK 3,5 doors	93-01	N/021		100	2600	12,75	-
RANGER (2/4WD)	99-12/11	E/043		115	3000	15,01	-
RANGER	12-	E/050		225	3500	17,20	-
S-MAX	06-12/15	E/038		100	2640	12,50	
		E/A38		100	2640	12,50	
S-MAX	05/15-	E/056		90	2000	12,10	
TRANSIT	01/86-04/00	E/026		75	2000	12,50	-
TRANSIT 2000	05/00-08/14	E/027		112	2800	15,33	-
TRANSIT	14-	E/054		140	3500	19,80	
TRANSIT pick-up	00-	E/035		120	3000	15,26	-
TRANSIT VAN, with footboard	05/00-08/14	E/040		112	2800	15,33	-
TRANSIT CONECT	02-12	E/055		75	1250	8,10	-
TOURNEO CUSTOM	13-	E/049		115	2800	14,91	-
WINDSTAR	95-01	E/022		75	1900	10,00	-
HONDA							
ACCORD CC, CE CF	93-09/98	H/002		70	1400	7,91	
ACCORD CG, CH	10/98-03	H/008		60	1500	8,32	
ACCORD berline	12/02-08	H/010		75	1500	8,35	
ACCORD TOURER	12/02-08	H/011		75	1500	8,51	
ACCORD SEDAN, TOURER	08-	H/022		75	1700	9,41	
CIVIC 5 doors	04/95-00	H/003		50	1300	6,93	
CIVIC 3D	92-00	H/014		50	1200	6,01	-
CIVIC 4D	04/06-08/11	H/025		75	1700	8,80	
CIVIC 4D	12-	H/026		75	1700	8,80	
		H/031		100	1500	9,65	
CIVIC 4D	06/17-	H/A31		100	1500	9,65	
CIVIC 5D	06/11-	H/029		75	1500	8,20	
CIVIC 5D	01/12-14	H/027		75	1500	8,32	
CIVIC 5D HB excl. TYPE R	01/17-	H/031		100	1500	8,50	
		H/A31		100	1500	8,50	
CRV	97-02/02	H/012		70	1500	8,00	
CRV	03/02-06	H/013		100	1500	8,65	-
CRV	01/07-09/12	H/015		100	2000	10,43	
CRV	10/12-	H/023		100	2000	10,39	-

 BRAND & MODEL	building year 	CAT NO.	 type of coupling	 vertical load	 max. towing weight	D-Value (kN)	 bumper cut
HR-V 3,5 doors	99-05/02	H/007		60	1400	7,32	
HR-V 5 doors	15-	H/028		70	1400	7,85	
		H/A28		70	1400	7,85	
HYUNDAI							
ACCENT	06/06-11	J/030		50	1400	7,50	
ACCENT	95-98	J/001		50	1400	7,00	-
ACCENT 3/5 doors 4 doors	08/99-05	J/009		50	1200	7,00	-
ATOS	98-04	J/002		50	700	4,40	-
GETZ 3/5 doors	02-12/04	J/019		44	1100	6,50	
GETZ 3/5 doors	05-09	J/031		50	1100	7,10	
i 10	01/08-06/15	J/036		30	700	5,25	-
i 20	06/09-08/14	J/040		50	1200	7,06	-
i30 htb.	06-10/11	K/021		75	1500	8,30	-
i30 htb.	12-	J/047		80	1500	8,30	-
i30 break	08-05/12	J/035		75	1500	8,70	-
i30 break	12-	K/044		75	1500	8,70	
i30 3/5D	01/17-	J/068		80	1500	8,30	
ix 30 Fastback	18-	J/066		85	1627	8,30	
		J/A66		85	1627	8,30	
I 40 sedan, break	04/11-	J/041		80	1200	9,92	
ix 20	10-	J/042		75	1300	7,40	
ix 35	08/10-12/15	J/038		80	2200	10,14	
		J/A38		80	2200	10,14	
KONA (excn. Ad blue)	17-	J/065		80	1250	7,41	
		J/A65		80	1250	7,41	
SANTA FE	01-05	J/018		90	2300	11,52	
SANTA FE	06-08/12	J/020		90	2850	16,30	
SANTA FE	09/12-	J/051		100	2500	12,60	-
TERRACAN	01-06	J/033		115	2800	13,80	-
TUCSON	04-08/12	K/020		80	2000	10,30	
TUCSON	2015-	K/062		90	2200	10,90	
		K/A62		90	2200	10,90	
TUCSON (excl. Ad Blue)	08/18-	J/069		100	2200	11,00	-
		J/A69		100	2200	11,00	-
MATRIX	01-08	J/032		55	1300	7,61	-
IVECO							
DAILY UNIWERS.	82-04/99	I/001		75	3500	22,50	-
DAILY UNIWERS.	05/99-	I/004		250	3500	22,50	-
DAILY VI 35S	14-	I/006		150	3500	23,00	-
DAILY VI 50	14-	I/007		200	3500	23,00	-

 BRAND & MODEL	building year 	CAT NO.	 type of coupling	 vertical load	 max. towing weight	D-Value (kN)	 bumper cut
JEEP							
CHEROKEE	88-01/97	J/021		130	3300	12,50	-
CHEROKEE	01-07	J/026		140	3500	14,40	-
CHEROKEE	03/08-13	J/050		140	3500	14,37	
CHEROKEE	04/13-	J/071		150	2500	12,40	
GRAND CHEROKEE	92-02/99	J/022		140	3500	14,31	-
GRAND CHEROKEE	03/99-05/05	J/025		140	3500	14,40	
GRAND CHEROKEE	06/05-05/11	J/027		140	3500	15,16	
GRAND CHEROKEE	06/11-	J/029		175	3500	15,70	-
COMMANDER	05/06-10	J/027		140	3500	15,16	
COMPASS (MK)	06-11	J/070		105	2000	10,11	
COMPASS	17-	J/072		100	1500	8,70	
		J/A72		100	1500	8,70	
PATRIOT	06-11	J/070		105	2000	10,11	
RENEGADE	09/14-	J/072		100	1500	8,70	
		J/A72		100	1500	8,70	
WRANGLER	04/07-	J/028		350	3500	15,30	-
KIA							
CARNIVAL	01/00-06	K/008		80	2000	8,66	
CARENS (FC)	00-06	K/012		75	1250	8,50	-
CEE'D htb	06-12	K/021		75	1500	8,30	-
CEE'D htb	06/12-	K/043		80	1500	8,30	-
CEE'D III 5D	18-	K/069		75	1500	8,41	
		K/A69		75	1500	8,41	
CEE'D break	07-08/12	K/023		75	1600	8,85	-
CEE'D break	09/12-	K/044		75	1500	8,70	-
CEE'D SW (estate)	18-	K/071		75	1500	8,41	
		K/A71		75	1500	8,41	
NIRO 5D	16-	K/066		100	1300	7,62	
		K/A66		100	1300	7,62	
MAGENTIS	01-06	K/024		75	1700	10,00	
MAGENTIS	06-10	K/025		80	1700	9,10	
RIO 4,5 d	00-05	K/013		45	1100	6,50	
RIO III 4D	12-	K/068		75	1200	7,87	-
SORENTO	02-06	K/014		120	2800	13,22	
SORENTO	07/06-09	K/022		140	3500	14,95	
SORENTO (X,M)	09-10/12	K/028		100	2500	12,30	-
SORENTO	12-15	J/051		100	2500	12,60	-
SORENTO	2015-	K/045		100	2500	12,60	
SOUL	08-13	K/026		52	1300	7,45	-
SPORTAGE	01/05-07/10	K/020		80	2000	10,30	

 BRAND & MODEL	building year 	CAT NO.	 type of coupling	 vertical load	 max. towing weight	D-Value (kN)	 bumper cut
SPORTAGE	08/10-12/15	J/038		80	2200	10,14	-
		J/A38		80	2200	10,14	-
SPORTAGE	09/15-	K/062		90	2200	10,90	
		K/A62		90	2200	11,00	
SPORTAGE excl. Ad Blue	08/18-	K/069		100	2200	11,00	-
		K/A69		100	2200	10,90	-
STONIC	17-	K/067		75	1110	6,60	
		K/A67		75	1110	6,60	
VENGA	09-	K/027		60	1300	7,65	
LANCIA							
DELTA II	2008-	F/024		75	1400	7,90	-
		F/A24		75	1400	7,90	
ZETA	94-01	P/016		80	1800	9,70	
PHEDRA	02-10	F/020		80	1900	10,20	-
LAND ROVER							
DEFENDER	98-	L/034		150	3500	17,17	-
EVOQUE	06/11-	L/032		150	1800	10,00	-
		L/A32		150	1800	10,00	-
FREELANDER MK I	98-07	L/010		140	2000	10,00	-
FREELANDER MK II	08-10/14	L/031		150	2300	11,08	
LUBLIN							
III 2,9 t VAN	99-	L/004		70	2000	11,82	-
III 3,5 t CONTAINER	99-	L/006		70	2000	12,49	-
III 3,5 t VAN	99-	L/005		70	2000	12,49	-
INTRALL pick-up	05-	L/007		70	2500	12,49	-
LADA							
NIVA	76-	L/104		50	1500	7,70	-
GAZ SOBOL VAN	07-	L/011		75	1200	8,48	-
GAZ SOBOL pick-up	07-	L/110		75	1200	8,48	-
MERCEDES							
124	85-05/95	M/002		75	1900	10,00	-
124 break	86-95	M/002		75	1900	10,00	-
SPRINTER 3,05 VAN	95-06	M/006		100	2800	15,26	-
SPRINTER 3,05 with footboard	95-06	M/018		100	2800	15,26	-
SPRINTER 3550/4025 VAN	95-06	M/007		120	2800	15,85	-
SPRINTER 3550/4025 with footboard	95-06	M/012		120	2800	16,05	-
SPRINTER pick-up, double tyres	95-06	M/014		100	2800	15,26	-
SPRINTER pick-up, single tyres	95-06	M/015		100	2800	15,26	-
SPRINTER 3,55/4025 VAN (single tyres)	04/06-	M/021		140	3500	20,20	-

 BRAND & MODEL	building year 	CAT NO.	 type of coupling	 vertical load	 max. towing weight	D-Value (kN)	 bumper cut
SPRINTER pick-up, 5T double tyres	04/06-	M/024		140	3500	20,20	-
SPRINTER 3,65/4 VAN, 32 with footboard (single tyres)	04/06-	M/031		100	2800	15,24	-
SPRINTER pick-up), 3T/3,5T/4,6T (single tyres)	06-	M/021		140	3500	20,20	-
TGE Furgon	11/16-	W/049		150	3500	17,17	-
VANEO WSA 638	02-	M/026		50	1200	7,40	-
VITO without PDC	96-08/03	M/008		75	2000	11,70	
VITO without PDC	09/03-08/14	M/020		100	2500	13,25	
VITO, V-klass	14-	M/050		100	2500	13,77	
		M/A50		100	2500	13,77	
VIANO without PDC W 639	08/03-08/14	M/020		100	2500	13,25	
A-SERIES (W-168)	97-04	M/017		50	1000	6,11	-
A-SERIES (W-169)	10/04-06/12	M/025		70	1500	8,65	
		M/A25		70	1500	8,65	
A-SERIES (HB)(W-176)	12-06/15	M/046		100	1600	9,35	
		M/A46		100	1600	9,35	
B SERIES (W-245)	06/05-10/11	M/025		70	1500	8,65	
		M/A25		70	1500	8,65	
B SERIES (W-246)	11/11-	M/046		100	1600	9,35	-
		M/A46		100	1600	9,35	
CITAN	10/12-	R/042		75	1350	7,62	-
E-SERIES (W-210)	06/95-03/02	M/019		100	2100	11,50	-
E-SERIES W 211 4 doors berline	02-09	M/027		75	2200	10,70	-
		M/A27		75	2200	10,70	-
E-SERIES break (W-210)	96-03/02	M/023		85	2100	11,02	-
E-SERIES S-211 (excl. AMG) break	03-09	M/041		130	2100	11,40	
		M/A41		130	2100	11,40	
E-SERIES W 212	09/09-12/15	M/048		88	2200	11,39	
E-SERIES S 212	09/09-	M/044		88	2100	11,64	-
C-SERIES W 202	93-05/00	M/011		75	1800	8,72	-
C-SERIES W 203 4 doors	06/00-07	M/032		75	1700	10,00	-
		M/A32		75	1700	10,00	-
C-SERIES W 203 break	04/01-07	M/032		75	1700	10,00	-
C-SERIES W-204 4 doors (excl. AMG)	08-14	M/034		100	2300	10,20	
		M/A34		100	1800	10,20	
C-SERIES W-204 4 doors excl. AMG	03/07-02/14	M/034		100	2300	10,20	
		M/A34		100	1800	10,20	
C-SERIES W 205 4 doors	14-	M/047		75	1900	10,22	-
		M/A47		75	1900	10,22	-

























































 BRAND & MODEL	building year 	CAT NO.	 type of coupling	 vertical load	 max. towing weight	D-Value (kN)	 bumper cut
CLA (C117)	4/13-	M/049		100	1800	9,52	-
		M/A49		100	1800	9,52	-
GLA (X156)	03/14-	M/049		100	1800	9,52	-
		M/A49		100	1800	9,52	-
GL X 164	05-12	M/042		135	3500	16,54	-
		M/A42		135	3500	16,54	-
GL (X166)(excl. AMG)	01/08-12/15	M/042		135	3500	16,54	-
		M/A42		135	3500	16,54	-
GLK	09/06-10/12	M/045		100	2400	11,97	
		M/A45		100	2400	11,97	-
GLS (X166)(excl. AMG)	01/08-12/15	M/042		135	3500	16,54	-
		M/A42		135	3500	16,54	-
ML W 164	05-12	M/043		135	3500	16,54	-
		M/A43		135	3500	16,54	-
X-Class	10/17-	N/054		140	3500	17,20	-
MAZDA							
B2500; BT50	99-05/12	E/043		115	3000	15,01	-
BT50	06/12-	E/050		225	3500	17,20	-
323 F 5 doors	98-03	X/012		75	1600	8,20	
3 hatchback	03-09	X/010		75	1765	8,71	
3 berline	09-06/13	X/021		75	1800	9,31	-
3 berline sports appearance pack	04-09	X/010		75	1765	8,71	-
5	02/05-09/10	X/019		75	1600	9,30	
5	01/11-	X/019		75	1600	9,30	
6 (5 doors)	01/03-01/08	X/011		75	1800	8,95	
6 break	01/03-01/08	X/013		75	1800	8,95	
6 hatchback, berline, break	08-01/13	X/018		100	1600	10,01	
6 berline	02/13-	X/025		75	1800	10,10	-
		X/030		75	1800	8,88	
CX-3	15-	X/A30		75	1800	8,88	
		X/023		88	2300	10,83	-
CX-5	11/11-01/17	X/031		100	2100	10,80	-
		X/A31		100	2100	10,80	-
CX-7	07-12	X/020		75	1700	10,00	
CX-9	07-	X/A22		85	1900	11,30	-
MPV. LW	04-09	X/014		85	2000	10,80	-
PREMACY VAN, 5 doors	99-05	X/016		75	1600	8,40	

 BRAND & MODEL	building year 	CAT NO.	 type of coupling	 vertical load	 max. towing weight	D-Value (kN)	 bumper cut
TRIBUTE/FORD MAVERICK	04-	X/015		90	1890	10,00	
mitsubishi							
ASX	10-	Y/028		80	1500	8,96	
		Y/A28		80	1500	8,17	
CARISMA hatchback berline	08/95-05	Y/001		75	1500	7,91	
L-200 pick-up	96-05	Y/009		100	2700	13,80	-
L-200	06-	Y/011		115	2700	14,10	-
L-200	10/09-	Y/025		115	2700	14,10	-
LANCER 4 doors	04-08	Y/014		75	1500	7,20	-
OUTLANDER	03-12/06	Y/021		75	1500	8,66	-
OUTLANDER	07-08/12	Y/024		100	2000	11,00	
		Y/A24		100	2000	11,00	
OUTLANDER	09/12-	Y/029		100	2000	11,00	-
PAJERO (V2/V4)	91-02/00	Y/006		120	3300	15,00	-
PAJERO/MONTERO 5 doors V70	00-06	Y/013		120	3000	15,20	-
PAJERO SWB/LWD V80/V90	02/07-08	Y/026		135	3300	15,81	-
PAJERO SPORT	98-08	Y/015		100	2800	13,60	-
SPACE STAR	98-06	Y/008		75	1400	7,63	
NISSAN							
ALMERA hatchback (N15)	09/95-02/00	N/001		75	1600	7,90	
ALMERA hatchback (N16)	03/00-06	N/014		75	1600	8,09	
ALMERA berline (N15)	09/95-02/00	N/002		75	1600	7,90	
ALMERA berline (N16)	03/00-06	N/019		75	1600	8,10	
ALMERA TINO	00-07	N/027		75	1650	8,40	
INTERSTAR	09/02-03/10	R/009		100	2300	13,62	-
JUKE 2WD	10/06-14; 07/14-	N/052		75	1550	8,50	
MICRA 3/5 doors K12	02/03-10/10	N/031		75	1300	6,78	
MURANO	05-07/08	N/035		80	1535	9,18	
		N/A35		80	1535	9,18	
MURANO (Z 51)	08/08-	N/039		100	1585	10,90	
		N/A39		100	1585	10,90	
NAVARRA with footboard double cab.	05/05-	N/025		120	3000	14,50	-
NAVARRA (pipe)	05/05-	N/033		120	3000	14,50	-
NAVARA (D40)	10/17-	N/054		140	3500	17,20	-
NV300 (L1, L2)	09/16-	R/066		100	2100	12,21	-
NV400	07/10-	R/061		100	2500	14,31	-
NOTE	06-13	N/038		50	1200	6,90	
QASHQAI (J10) (J+2) (J11)	06-01/14,14-	N/032		75	1600	8,50	
		N/A32		75	1600	8,50	
PATROL Y61	98-04	N/023		140	3500	16,30	-



























































 BRAND & MODEL	building year 	CAT NO.	 type of coupling	 vertical load	 max. towing weight	D-Value (kN)	 bumper cut
PATROL Y61	04-10	N/023		140	3500	16,30	-
Pick-up, D22 4WD	02-	N/017		110	3000	13,00	-
PRIMASTAR	09/02-	R/024		80	2000	11,70	-
PRIMERA break W11	98-02	N/018		75	1700	9,00	
PRIMERA P11 hatchback berline	09/99-02/02	N/016		75	1700	8,40	
PRIMERA 4,5 doors P12	03/03-	N/024		75	1500	9,40	
PRIMERA P12 break	09/01-05/07	N/034		75	1850	9,40	
TERRANO II 3,5 doors	93-03	N/021		100	2600	12,75	-
X-TRAIL (T30)	03/03-02/07	N/022		100	2300	11,20	
X-TRAIL (T31)	03/07-14	N/036		100	2200	10,60	
X-TRAIL	14-05/17	N/053		110	2200	11,10	
		N/A53		110	2200	11,10	
X-TRAIL	06/17-	R/069		100	2000	10,50	
		R/A69		100	2000	10,50	
OPEL							
ASTRA F hatchback (F, A)	09/91-02	O/003		75	1500	8,10	
ASTRA F berline (F, A)	91-02	O/004		75	1500	8,10	-
ASTRA F break (F, A)	96-02	O/006		75	1500	8,10	-
ASTRA II G hatchback berline (G, B)	03/98-04	O/007		75	1500	8,50	-
ASTRA II G break (G, B)	03/98-04	O/008		75	1500	8,50	-
ASTRA III H hatchback	03/04-09	O/030		75	1650	8,97	-
		O/A30		75	1650	8,97	-
ASTRA III H break	10/04-09/10	O/031		75	1650	8,97	-
		O/A31		75	1650	8,97	-
ASTRA J htb	09/09-10/15	O/039		75	1500	9,60	-
		O/A39		75	1500	9,60	-
ASTRA J break	10/10-10/15	O/040		75	1800	9,60	-
		O/A40		75	1800	9,60	-
ASTRA K HB (5D)	10/10-10/15	O/047		75	1800	9,60	
		O/A47		75	1800	9,60	
ASTRA K estate Sport Turier	10/10-10/15	O/046		75	2100	10,01	
		O/A46		75	2100	10,01	
CORSA B hatchback	03/93-09/00	O/010		50	1100	5,90	
CORSA C	10/00-06	O/024		50	1200	7,10	
CORSA D	06-08/15	O/033		55	1350	7,66	
CORSA E	2015-	O/033		55	1350	7,66	
COMBO	09/01-11	O/023		50	1200	7,49	
COMBO	11-	F/031		65	1620	9,79	-
COMBO III (L2)	06/18-	C/045		75	1600	9,43	
		C/A45		75	1600	9,43	









































 BRAND & MODEL	building year 	CAT NO.	 type of coupling	 vertical load	 max. towing weight	D-Value (kN)	 bumper cut
COMBO III (L1 4403)	03/18-	C/029		80	1600	8,69	-
		C/A29		80	1600	8,69	-
COMBO	03/18-	C/029		80	1600	8,69	-
		C/A29		80	1600	8,69	-
FRONTERA	10/98-06	O/036		112	2800	12,90	-
FRONTERA	91-09/98	O/037		78	1950	13,30	-
GRANDLAND X	17-	P/044		100	2000	10,10	
		P/A44		100	2000	10,10	
INSIGNIA NB, HB, break	08-05/17	O/038		85	2000	11,00	
		O/A38		85	2000	11,00	
INSIGNIA 5D Grand Sport	06/17-	O/045		90	2400	11,60	
		O/A45		90	2400	11,60	
MERIVA	03-04/10	O/035		60	1360	7,60	
MERIVA B	05/10-	O/041		75	1300	8,30	
MOKKA	12-	O/044		75	1500	8,75	-
		O/A44		75	1500	8,75	-
MOVANO, van, minibus	99-03/10	R/009		100	2300	13,62	-
MOVANO VAN FWD	04/10-	R/046		100	2500	14,31	-
MOVANO VAN RWD	07/10-	R/051		100	2500	14,31	-
MOVANO PICK-UP	07/10-	R/052		100	2500	14,31	-
OMEGA A berline	86-03	O/028		75	2100	10,90	-
OMEGA A break	86-03	O/022		75	2100	11,00	-
SINTRA	96-00	O/029		75	1820	10,80	-
VECTRA B htb, berline	10/95-08/98	O/018		75	1700	9,30	-
VECTRA B break	96-08/98	O/018		75	1700	9,30	-
VECTRA B berline	09/98-05/02	O/018		75	1700	9,30	-
VECTRA break	09/98-02	O/018		75	1700	9,30	-
VECTRA C hatchback berline	06/02-	O/026		80	1950	10,72	-
		O/A26		80	1950	10,72	
VECTRA C break	02-	O/027		85	2000	10,72	-
		O/A27		85	2000	10,72	
ZAFIRA	99-06/05	O/019		75	1600	8,91	-
ZAFIRA II	07/05-12/11	O/034		75	1650	9,60	
		O/A34		75	1650	9,60	
ZAFIRA C	01/12-	O/042		75	1500	9,90	
VIVARO	01-07/14	R/024		80	2000	11,70	-
VIVARO (L1, L2)	07/14-	R/066		100	2100	12,21	-
PEUGEOT							
106	96-04	P/013		50	1100	6,10	-
206	98-03/03	P/003		50	1100	6,39	-























































 BRAND & MODEL	building year 	CAT NO.	 type of coupling	 vertical load	 max. towing weight	D-Value (kN)	 bumper cut
206	04/03-09	P/023		50	1100	6,39	
206 +	09-	P/023		50	1100	6,39	
206 SW break	02-07	P/022		50	1100	6,30	-
207 hatchback, coupe, cabrio	06-12/15	P/031		50	1150	6,70	
		P/A31		50	1150	6,70	
207 SW	07-10/13	P/034		50	1150	6,88	
		P/A34		50	1150	6,88	
208 HTB	12-	P/040		55	1300	7,20	-
		P/A40		55	1300	7,20	-
306 break	97-02	P/006		50	1200	7,00	-
307 hatchback	01-07	P/021		60	1500	8,06	-
307 SW break	01-08	P/024		70	1700	9,10	-
308 hatchback	07-02/14	P/021		60	1500	8,06	-
308 hatchback	11/13-	C/039		70	1750	9,56	-
308 break	03/08-02/14	P/035		77	1650	9,32	-
308 break	03/14-	C/039		75	1750	9,56	-
406 berline	95-04	P/010		75	1700	8,60	
406 break	95-04	P/014		75	1700	8,65	-
407 berline 4 doors	04-	P/032		75	1600	9,55	-
407 break	04-	P/033		65	1600	9,19	-
508 sedan	03/11-	P/039		80	2250	10,80	
		P/A39		80	2250	10,80	
508 SW break	03/11-	P/038		75	1900	10,19	-
		P/A38		75	1900	10,19	-
1007	03/05-	C/016		50	1100	6,10	
2008	04/13-	P/043		60	1300	7,24	-
		P/A43		60	1300	7,24	-
3008	09-04/16	P/036		75	1600	9,20	
		P/A36		75	1600	9,20	
3008 II	05/16-	P/044		100	2000	10,10	
		P/A44		100	2000	10,10	
4007	07-	Y/024		100	2000	11,00	
		Y/A24		100	2000	11,00	
4008	12-	Y/028		70	1500	8,96	
		Y/A28		70	1500	8,96	
5008	10/09-04/17	P/037		100	1700	9,70	-
		P/A37		100	1700	9,70	-
5008	05/17-	P/045		100	2000	10,10	
		P/A45		100	2000	10,10	
806	94-02	P/016		80	1800	9,70	

 BRAND & MODEL	building year 	CAT NO.	 type of coupling	 vertical load	 max. towing weight	D-Value (kN)	 bumper cut
807	02-14	F/020		80	1900	10,20	
EXPERT I	94-12/06	P/016		80	1800	9,70	-
EXPERT II	07-	F/023		80	2000	11,93	
		F/A23		80	2000	11,93	
EXPERT III	16-	C/042		100	2500	13,60	-
		C/A42		100	2500	13,60	-
BIPPER	08-	F/027		60	1100	6,83	-
BOXER	04/94-12/02	C/005		110	2200	12,49	-
BOXER	03-06/06	C/005		110	2200	12,49	-
BOXER III VAN, L1 L2 L3	07/06-	C/018		100	3000	15,09	
BOXER III VAN, L4	06-	C/030		120	3100	16,13	
BOXER III pick-up, L1 L2 L3	06-	C/025		120	3100	15,09	-
PARTNER I	11/96-07	C/012		70	1100	7,00	
PARTNER II vehicle lenght 4380	02/08-	C/029		80	1600	8,69	-
		C/A29		80	1600	8,69	
PARTNER LWD 4680	05/08-	C/036		65	1600	8,69	-
		C/A36		65	1600	8,69	-
PARTNER III (L2) (4753)	06/18-	C/045		75	1600	9,43	
		C/A45		75	1600	9,43	
PARTNER (L1 4403)	03/18-	C/029		80	1600	8,69	-
		C/A29		80	1600	8,69	-
RIFTER XL (L2) (4753)	06/18-	C/045		75	1600	9,43	
		C/A45		75	1600	9,43	
RIFTER (L1 4403)	03/18-	C/029		80	1600	8,69	-
		C/A29		80	1600	8,69	-
RIFTER (chassis model L1)	03/18-	C/029		80	1660	8,69	-
		C/A29		80	1660	8,69	-
POLONEZ							
CARO/ATU/break plus	97-	P/19		50	1200	6,10	-
TRUCK (plastik)	98-	P/17		50	1500	6,10	-
RENAULT							
ALASKAN	10/17-	N/054		140	3500	17,20	-
CAPTUR	13-	R/057		75	1200	7,20	-
CLIO I	90-98	R/015		50	1100	5,80	-
CLIO II	98-09/04	R/016		75	1200	6,67	-
CLIO III, htb.	09/05-12/14	R/033		75	1200	7,00	
CLIO IV, htb.	11/12-	R/054		75	1200	7,06	-
CLIO III break	11/08-12/12	R/047		75	1200	7,69	-
CLIO IV break, grandtour	13-	R/055		75	1200	7,69	-
ESPACE J66/JE	96-10/02	R/019		85	1900	10,61	

 BRAND & MODEL	building year 	CAT NO.	 type of coupling	 vertical load	 max. towing weight	D-Value (kN)	 bumper cut
ESPACE	02-01/15	R/034		80	2000	11,29	-
		R/A34		80	2000	11,29	-
ESPACE	15-	R/061		80	2000	10,84	-
FLUENCE	11/09-	R/058		75	1300	7,50	
GRAND ESPACE J66/JE	01/98-10/02	R/019		85	2000	10,61	
GRAND ESPACE	02-12/15	R/035		80	2000	11,29	-
		R/A35		80	2000	11,29	-
GRAND scenic II	04/04-06/09	R/029		75	1350	8,02	
KADJAR	15-	R/059		75	2000	12,81	-
KANGOO	97-08	R/006		75	1350	7,73	-
KANGOO II	08-	R/042		75	1350	7,62	-
KOLEOS	08-12/16	R/041		100	2000	10,50	-
		R/A41		100	2000	10,50	-
KOLEOS II	17-	R/069		100	2000	10,50	
		R/A69		100	2000	10,50	
LAGUNA I hatchback	04/94-00	R/007		75	1650	9,76	-
LAGUNA II hatchback 5d	01-07	R/020		75	1600	8,50	-
LAGUNA III hatchback	10/07-	R/043		75	1500	8,80	-
		R/A43		75	1500	8,80	
LAGUNA I break	09/95-00	R/008		75	1850	9,30	-
LAGUNA II break	01-07	R/018		75	1500	8,50	-
LAGUNA III break	10/07-	R/037		75	1500	9,76	
		R/A37		75	1500	9,76	
LATITUDE	10/10-	R/060		75	1500	8,75	
		R/A60		75	1500	8,75	
MASTER VAN, pick-up	98-03/10	R/009		100	2300	13,62	-
MASTER VAN FWD	04/10-	R/046		100	2500	14,31	-
MASTER VAN RWD	07/10-	R/051		100	2500	14,31	-
MASTER PICK-UP	07/10-	R/052		100	2500	14,31	-
MEGANE I hatchback	96-03/99	R/010		65	1300	7,20	-
MEGANE I hatchback	04/99-10/02	R/031		75	1350	6,20	-
MEGANE II hatchback	11/02-08	R/030		75	1350	7,56	-
MEGANE III hatchback	03/09-08/15	R/045		75	1300	7,44	
		R/A45		75	1300	7,44	
MEGANE IV (5D)	02/16-	R/071		75	2170	10,00	
		R/A71		75	2170	10,00	
MEGANE I berline (classic)	96-02	R/014		75	1350	7,30	-
MEGANE II berline (classic)	03-05/10	R/028		75	1300	7,73	-
MEGANE I break	03/99-07/03	R/036		75	1350	7,30	-
MEGANE II break, grand tour	07/03-10/08	R/028		75	1350	7,73	-

 BRAND & MODEL	building year 	CAT NO.	 type of coupling	 vertical load	 max. towing weight	D-Value (kN)	 bumper cut
MEGANE III break, grand tour	11/08-08/15	R/048		75	1500	8,41	-
MEGANE estate Grandtour	09/16-	R/071		80	2145	10,10	
		R/A71		80	2145	10,10	
MEGANE scenic I (excl. 2.0)	01/97-07/99; 08/99-03	R/011		75	1400	8,00	-
MEGANE GRAND COUPE	17-	R/068		75	1850	9,25	-
		R/A68		75	1850	9,25	-
MEGANE SCENIC II	03-09	R/029		75	1350	8,02	
		R/A29		75	1350	8,02	
MEGANE SCENIC III	07/09-	R/049		75	1400	8,24	
		R/A49		75	1400	8,24	
MEGANE GRAND SCENIC III	04/09-	R/050		75	1400	8,24	
		R/A50		75	1400	8,24	
SCENIC, GRAND SCENIC	17-	R/064		75	1948	10,50	
		R/A64		75	1948	10,50	
TALISMAN SEDAN	15-	R/062		80	2000	10,10	-
		R/A62		80	2000	10,10	-
TALISMAN, COMBI	15-	R/063		80	2000	10,10	-
		R/A63		80	2000	10,10	-
TRAFIC	01-14	R/024		80	2000	11,70	-
TRAFIC	14-	R/066		100	2100	12,21	-
THALIA	99-07/08	R/026		75	1100	6,70	-
THALIA	08/08-	R/026		75	1100	6,70	-
SEAT							
ALTEA	05/04-	S/013		75	1600	8,91	
ALTEA XL	11/06-	S/013		75	1600	8,91	
ARONA HB	07/17-	S/018		60	1400	7,50	-
		S/A18		60	1400	7,50	-
AROSA	97-04	S/008		50	850	5,17	
ALHAMBRA	95-04/00	E/010		85	2100	11,20	-
ALHAMBRA	05/00-09/10	E/030		100	2100	12,50	-
ALHAMBRA	10/10-	W/038		100	2500	12,50	
CORDOBA (CLX, GLX, GTI, SX)	02/96-12/02	S/002		50	1200	6,40	
CORDOBA VARIO break	97-12/02	S/002		50	1200	6,40	
CORDOBA berline	01/03-09	S/011		50	1200	6,96	
EXEO; EXEO ST	09-13	S/014		80	2000	10,71	-
		S/A14		80	2000	10,71	-
IBIZA	04/93-01/96	S/005		50	1100	6,60	-
IBIZA	09/99-04/02	S/002		50	1200	6,40	
IBIZA	05/02-08	W/022		50	1200	6,90	

 BRAND & MODEL	building year 	CAT NO.	 type of coupling	 vertical load	 max. towing weight	D-Value (kN)	 bumper cut
IBIZA htb, coupe	03/08-	S/015		75	1200	6,95	-
		S/A15		75	1200	6,95	-
IBIZA	01/17-	S/017		75	1200	6,92	-
		S/A17		75	1200	6,92	-
IBIZA break	06/10-	S/015		75	1200	6,95	-
		S/A15		75	1200	6,95	-
INCA	11/95-03	S/006		50	1100	6,30	-
LEON	03/00-05	W/018		75	1600	8,60	
LEON SC, ST FR, X-PERIENCE	13-	Z/016		100	1800	9,50	
TOLEDO STELLA	04/99-05	S/009		75	1600	8,70	
TOLEDO	05-09	S/013		75	1600	8,91	
		S/A13		75	1600	8,91	
TOLEDO htb.	13-	Z/017		75	1500	8,00	
TOLEDO berline	13-	Z/018		75	1500	8,00	
SKODA							
FABIA hatchback	99-	Z/006		50	1200	6,50	
FABIA break, berline	01-	Z/007		50	1000	6,20	
FABIA III htb	15-	Z/025		85	1415	7,50	
		Z/A25		85	1415	7,50	
FABIA III estate	15-	Z/025		85	1415	7,50	
		Z/A25		85	1415	7,50	
KAROQ	2017	Z/024		90	2000	10,80	
		Z/A24		90	2000	10,80	
KODIAQ	17-	Z/023		140	2500	12,62	
		Z/A23		140	2500	12,62	
OCTAVIA hatchback	96-10	Z/005		75	1600	8,60	
OCTAVIA break	98-10	Z/005		75	1600	8,60	
OCTAVIA I 4x4	98-10	Z/010		75	1750	8,60	
OCTAVIA II 5 doors, break	04-13	Z/011		75	1700	9,30	
		Z/A11		75	1700	9,30	
OCTAVIA RS, COMBI RS, SCOUT	13-	Z/016		100	1800	9,50	
RAPID HTB	13-	Z/017		75	1500	8,00	
RAPID spaceback, berline	10/12-	Z/018		75	1500	8,00	
ROOMSTER	06-	Z/012		60	1200	6,73	
SUPERB I	02-08	W/012		85	2000	10,20	
SUPERB II	08-05/15	Z/013		75	1795	9,58	-
		Z/A13		75	1795	9,86	
SUPERB II break	10-05/15	Z/013		75	1795	9,58	-
		Z/A13		75	1795	9,86	







 BRAND & MODEL	building year 	CAT NO.	 type of coupling	 vertical load	 max. towing weight	D-Value (kN)	 bumper cut
SUPERB III	03/15-	W/041		100	2235	11,50	
YETI	09-12/13	Z/015		80	2000	10,00	-
YETI	14-	Z/020		80	2000	10,00	
SSANG YONG							
ACTYON	06-	S/053		117	2300	10,05	-
KYRON	05-	S/052		92	2300	11,82	-
REXTON	07/06-	S/051		140	2000	15,14	-
SUBARU							
FORESTER	99-08	U/001		75	2000	10,00	-
FORESTER	08-13	U/005		80	2000	10,00	-
		U/A05		80	2000	10,00	
FORESTER	13-	U/007		80	2150	10,10	-
LEGACY OUTBACK	09-	U/006		82	2000	10,05	-
		U/A06		82	2000	10,05	-
OUTBACK	15-	U/009		90	2000	10,52	
		U/A09		90	2000	10,52	
TRIBECA	09/06-01/14	U/003		80	2000	11,10	-
		U/A03		80	2000	11,10	-
SUBARU XV	2017-	U/010		90	1400	9,05	-
SUZUKI							
GRAND VITARA	98-04	V/027		75	1850	9,80	-
GRAND VITARA 5 doors	05-	V/026		85	2000	10,50	
SWIFT 3, 5 doors	89-98	V/029		50	1000	5,45	-
SX4 (APV) 2WD, 4WD (RW)	06-12/15	F/026		75	1250	7,30	
		F/A26		75	1250	7,30	
SX4 s-cross (AK)	13-	V/032		75	1500	8,30	
VITARA	15-	V/050		75	1500	8,44	
VITARA distance mounting points 810	10/88-97	V/025		50	1500	7,23	-
VITARA 5 doors distance mounting points 820	95-04	V/028		75	1875	9,20	-
TOYOTA							
AURIS HTB 3/5 doors	06-12	T/035		60	1600	8,60	-
AURIS HTB 5 doors	10/12-	T/069		75	1600	8,80	-
AURIS break (excl hybrid)	06/13-	T/060		75	1300	8,60	-
AVENSIS liftb. berline T22	98-12/02	T/001		75	1400	8,30	
AVENSIS liftb. berline	03-09	T/023		75	1400	8,61	-
AVENSIS berline	09-	T/036		75	1800	10,70	-
		T/A36		75	1800	10,70	
AVENSIS break T22	97-12/02	T/011		75	1500	8,30	
AVENSIS break	03-09	T/024		75	1400	8,61	-

 BRAND & MODEL	building year 	CAT NO.	 type of coupling	 vertical load	 max. towing weight	D-Value (kN)	 bumper cut
AVENSIS break	09-	T/037		75	1800	10,70	-
		T/A37		75	1800	10,70	
AVENSIS VERSO	04/02-	T/025		75	1750	9,70	
C - HR 5D	10/16-	T/070		80	1500	8,70	-
		T/A70		80	1500	8,70	-
CARINA E liftb. berline (T19)	02/92-97	T/004		75	1400	7,63	
CARINA E break (T19)	11/92-97	T/020		75	1400		-
COROLLA hatchback (E10)	05/92-06/97	T/006		75	1300	7,06	-
COROLLA hatchback (E11)	07/97-02	T/006		75	1200	7,06	-
COROLLA hatchback (E12)	01/02-07	T/021		50	1350	7,91	-
COROLLA htb (5D) (incl. hybrid)	19-	T/070		80	1638	8,70	
		T/A70		80	1638	8,70	
COROLLA berline (E10)	05/92-06/97	T/007		75	1300	7,30	-
COROLLA liftb. berline (E11)	07/97-01	T/007		75	1300	7,30	-
COROLLA berline (E15)	07-10	T/045		60	1800	8,60	-
COROLLA berline (E18)	06/13-	T/061		60	1300	8,60	-
COROLLA sedan (incl. Hybrid)	19-	T/071		80	1980	9,41	
		T/A71		80	1980	9,41	
COROLLA break E12	02-07	T/019		55	1300	7,91	-
COROLLA Turing Sports (incl. Hybrid)	19-	T/071		80	1980	9,41	
		T/A71		80	1980	9,41	
COROLLA VERSO E12	02-03/04	T/031		55	1400	8,21	-
COROLLA VERSO R1	04/04-03/09	T/032		60	1450	8,61	
HIACE (H12/18/22/28)	09/95-	T/009		75	2000	11,79	-
HIGHLANDER	11-	T/050		120	2200	12,25	-
HIGHLANDER	14-	T/057		120	2200	12,25	-
HILUX 4x4, tyres 15"	05-10	T/030		120	2500	13,80	-
HILUX	08/10-	T/046		120	2800	13,80	-
LANDCRUISER J90	04/96-12/02	T/016		130	2800	13,73	-
LANDCRUISER 5 doors J12	01/03-	T/028		130	2800	16,30	
LANDCRUISER J150	11/09-	T/028		130	2800	16,30	
LANDCRUISER J200	08-	T/039		140	3500	17,40	-
		T/A39		140	3500	17,40	-
LEXUS RX300, 350, 400	03-09	T/033		100	2400	11,80	
LEXUS RX350,RX450H	09-	T/044		85	2100	11,86	
PROACE	01/16-	C/042		100	2500	13,60	-
		C/A42		100	2500	13,60	-
RAV-4 (A10/11)	94-05/00	T/017		75	1750	8,20	-
RAV-4	05-04/10	T/027		90	2050	10,41	-

 BRAND & MODEL	building year 	CAT NO.	 type of coupling	 vertical load	 max. towing weight	D-Value (kN)	 bumper cut
RAV-4 5 doors, 4x4, tyres 15/70, R16	00-05	T/026		75	1745	8,80	-
RAV-4	02/13-	T/041		80	2000	10,90	
RAV-4	11/18-	T/072		80	2000	10,90	
		T/A72		80	2000	10,90	
SIENNA	06-	T/040		75	1800	11,00	
VERSO	09-	T/042		55	1300	8,60	
VERSO S	01/11-	T/043		50	900	5,84	
YARIS hatchback (C,E) 3/5 doors	99-05	T/022		50	900	5,37	-
YARIS	05-	T/038		50	1000	6,30	
YARIS Verso	00-05	T/034		50	900	5,37	-
VOLKSWAGEN							
AMAROK	08/10-	W/035		120	2800	14,30	
BORA break	99-04	W/009		75	1600	8,91	
BORA berline	98-	W/018		75	1600	8,60	
GOLF III	11/91-03/98	W/004		75	1500	8,30	-
GOLF III break	08/93-99	W/005		75	1600	8,34	
GOLF IV	10/97-11/03	W/018		75	1600	8,60	
GOLF IV break	98-12/06	W/009		75	1600	8,91	
GOLF V hatchback	12/03-02/08	W/028		75	1850	9,20	
GOLF V PLUS	05-14	W/028		75	1850	9,20	
GOLF V break	05/07-06/09	W/030		75	1742	9,20	
GOLF VI break	07/09-13	W/030		75	1742	9,20	
GOLF VI	-	W/028		75	1850	9,20	
		Z/016		100	1800	9,50	
GOLF VII GTI, SPORTSVAN	12-	Z/A16		100	1800	9,50	
JETTA	06/05-01/11	W/030		75	1742	9,20	
JETTA	01/11-	W/037		75	1800	9,30	
CADDY	11/95-03	S/006		50	1100	6,70	-
CADDY	02/04-	W/027		80	1650	9,40	-
		W/A27		80	1650	9,40	-
CRAFTER 3665/4350 VAN	06-	M/021		140	3500	20,20	-
CRAFTER 3665/4350 pick-up, 5T	06-	M/024		140	3500	20,20	-
CRAFTER 3,65/4,32 furg. with footboard	04/06-	M/031		140	2800	15,24	-
CRAFTER pick-up, 3T; 3,5T; 4,6T	06-	M/021		150	3500	20,20	-
CRAFTER II furgon	11/16-	W/49		150	3500	17,17	-
CRAFTER II skrz. single tyres	11/16-	W/50		140	3000	15,85	-
LT 28-35 3,05 m	95-06	M/006		100	2800	16,24	-
LT 28-35 3,05 m with footboard	95-06	M/018		100	2800	15,26	-

 BRAND & MODEL	building year 	CAT NO.	 type of coupling	 vertical load	 max. towing weight	D-Value (kN)	 bumper cut
LT 28-35 3,55 m, 4,025 m	95-06	M/007		120	3000	15,85	-
LT 28-35 3,55 m, 4,025 with footboard	95-06	M/012		120	2800	16,05	-
LT 28-35 pick-up (skrz.), double tyres	95-06	M/014		100	2800	15,26	-
LT 28-35 pick-up (skrz.), single tyres	95-06	M/015		100	2800	15,26	-
PASSAT CL berline, break	04/88-09/93	W/010		85	2000	9,81	
PASSAT B-4 berline, break	10/93-09/96	W/011		85	2000	9,81	
PASSAT B-5 berline, break	10/96-09/00	W/012		85	2000	10,20	-
PASSAT B-5 4x4	10/96-	W/020		85	2200	11,30	-
PASSAT B-5 berline, break	10/00-02/05	W/012		85	2000	10,20	-
PASSAT B-6 berline, break	03/05-10	W/026		85	2000	10,20	
		W/A26		85	2000	10,20	
PASSAT B-7 sedan, break	10/10-12/14	W/036		90	2200	11,30	
PASSAT (T3G)	08/14-	W/041		100	2235	11,50	
POLO hatchback (6N)	10/94-08/99	W/021		50	1200	6,73	
POLO hatchback (6N)	09/99-01/02	W/021		50	1200	6,73	
POLO hatchback 9N	02/02-05/09	W/022		50	1200	6,90	
POLO htb.	05/09-	W/034		85	1350	7,50	
POLO	01/17-	S/017		75	1200	6,92	-
		S/A17		75	1200	6,92	-
POLO CLASSIC berline	11/95-05/03	S/002		50	1200	6,40	
POLO break (6K)	97-01	S/002		50	1200	6,40	
SHARAN	06/95-04/00	E/010		85	2100	11,20	-
SHARAN	05/00-09/10	E/030		100	2100	12,50	-
SHARAN	07/10-06/12	W/038		100	2500	12,50	
SHARAN 5D VAN	06/12-	W/046		100	2500	12,50	-
		W/A46		100	2500	12,50	-
T-4 Furgon	09/90-01/96	W/016		100	2500	13,00	-
T-4 Furgon	01/96-12/02	W/016		100	2500	13,00	-
T-4 pick-up	09/90-02	W/024		100	2500	13,10	-
VW TRANSPORTER T5 pick-up	01/03-	W/029		100	2500	14,40	-
T-5, T-6	01/03-	W/023		120	2800	14,18	-
T-ROC	2018-	W/047		90	1900	11,89	
		W/A47		90	1900	11,89	
TOURAN	03/03-09/15	W/025		75	1825	9,90	
		W/A25		75	1825	9,90	
TOURAN	10/15-	W/043		80	1800	9,92	
		W/A43		80	1800	9,92	
TOUAREG	03-12/14	W/031		140	3500	16,40	
		W/A31		140	3500	16,40	

 BRAND & MODEL	building year 	CAT NO.	 type of coupling	 vertical load	 max. towing weight	D-Value (kN)	 bumper cut
TOUAREG	06/18-	W/038		75	1500	9,80	
		W/A38		75	1500	9,80	
TIGUAN	07-12/15	W/033		100	2500	12,00	
		W/A33		100	2500	12,00	
TIGUAN	16-	Z/023		140	2500	12,62	
		Z/A23		140	2500	12,62	
VOLVO							
S 40 berline/V 40 break	95-06/00	V/004		75	1500	8,50	
S 40 berline/V 40 break	07/00-03/04	V/004		75	1500	8,50	-
S 40	04-	V/014		75	1600	8,91	-
		V/A14		75	1600	8,91	-
V 40 5D CROSS COUNTRY	10/12-	V/038		75	1500	9,80	
		V/A38		75	1500	9,80	
V 50	04/04-	V/016		75	1600	8,91	-
		V/A16		75	1600	8,91	-
S70 berline /V 70 break/850 berline	97-02/00	V/007		90	1944	10,80	-
V60	09/10-	V/033		90	1950	10,80	-
V70	3/00-06/07	V/009		75	2000	10,30	-
		V/A09		75	2000	10,30	-
V70	09/07-	V/015		90	2100	11,00	
		V/A15		90	2100	11,00	
XC 40	10/17-	V/037		110	2157	10,80	
		V/A37		110	2157	10,80	
XC 60	11/08-12/16	V/017		90	2100	10,99	
		V/A17		90	2100	10,99	
XC 60	2017-	V/035		140	2400	12,40	
		V/A35		140	2400	12,40	
XC 70	10/07	V/020		90	2100	10,99	
		V/A20		90	2100	10,99	
S60	06/10-	V/033		90	1950	10,80	
S60	11/00-08/04	V/036		85	1600	9,10	
S80	98-05	V/011		90	2000	12,20	
S80	06-	V/018		90	2100	11,00	
		V/A18		90	2100	11,00	
XC90	03-14	V/012		75	2250	10,30	
		V/A12		75	2200	10,30	
XC90	15-	V/034		140	2844	13,40	
		V/A34		140	2844	13,40	

 BRAND & MODEL	building year 	CAT NO.	 type of coupling	 vertical load	 max. towing weight	D-Value (kN)	 bumper cut
USA TOWBALL							
USA TOWBALL		AM/101		150	3500	18,50	
USA TOWBALL		AM/102		200	3500	22,50	
USA TOWBALL		AM/103		100	2000	12,49	
TOWBALL		SM/200		112	3500	19,80	

ACCESSORIES	TYPE
Ball	
Ball	
Standard wiring kits 1,45 m	W145
Standard wiring kits 1,75 m	W175
Standard wiring kits 2,20 m	W220
Module UniKIT - 2	UniKit – 2
Module UniKIT - 2 P	UniKIT - 2 P
Module UniKIT - 3	UniKIT - 3
Module UniKIT - 3 P	UniKIT - 3 P

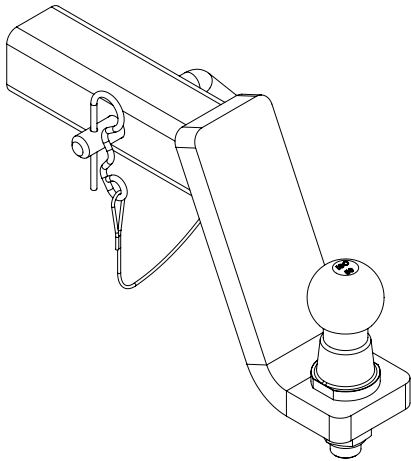

Type AM-101

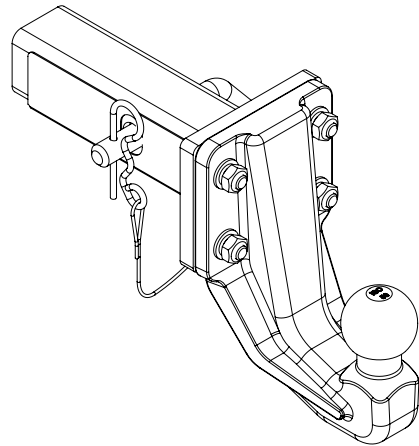

Type AM-102

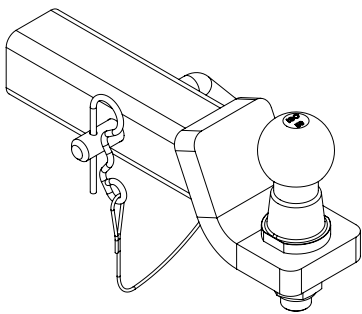

Type AM-103

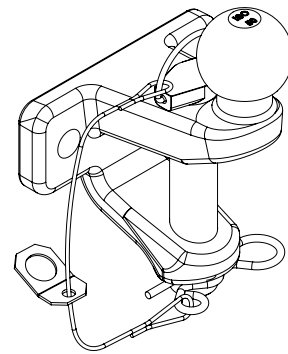

Type SM-200

NOTES

A series of horizontal dotted lines spanning the width of the page, providing a template for writing notes.